

Large Diameter Flange Adaptors OD816 - 1668mm to BS EN 1092-1 PN16 Drilling

Datasheet

3/4

Flange Adaptor

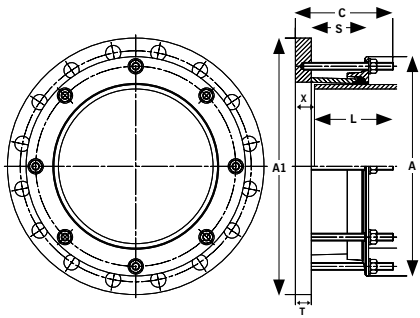

Flange Adaptor Type	Flange Adaptor Section	Sleeve Length S (mm)	Distance L (mm)	Setting Gap X (mm)		Bolt Details		
				Min.	Max.	Bolt Dia.	Length (mm)	Torque (Nm)
Standard Sleeve	L02	73	150	25	50	M12	140	55 - 65
Long Sleeve	L03	123	200	25	100	M12	180	55 - 65
Standard Sleeve	YF2	87	150	32	76	M16	160	95 - 120
Long Sleeve	YF3	123	200	32	115	M16	190	95 - 120
Standard Sleeve	A2E	87	150	32	76	M16	160	95 - 120
Long Sleeve	A2H	125	200	32	115	M16	190	95 - 120
Standard Sleeve	XSVG	254	200	57	117	M16	400	95 - 120

L = Distance back from end of pipe that must be rounded, meet tolerances, and free from any wrapping to ensure correct assembly.

Large Diameter Flange Adaptors (BS EN 1092-1 PN16 Drilling)

Pipe OD (mm)	Pipe Material	Flange Drilling BS EN 1092-1		Tolerance on Pipe OD for Distance L		Gasket Mould No.	No. Notches In End Ring If Required	Flange Adaptor Section Type		Flange Adaptor Studs No. x Dia	Weight (kg)		Dimensions						Flange Adaptor Studs Length	
		Nominal	Drilling	(mm) +	(mm) -			Standard Sleeve	Long Sleeve		Standard Sleeve	Long Sleeve	Diameter A (mm)	Flange OD A1 (mm)	Flange Thickness T (mm)	Flange Bolts No. x Dia	Overall C Standard Sleeve (mm)	Overall C Long Sleeve (mm)	Standard Sleeve	Long Sleeve
816	Coated Steel	800	PN16	1.6	1.6	J65LS	6	L02	L03	12 x M12	68.9	76.4	906	1025	23	24 x M36	153	193	140	180
842	Ductile Iron	800	PN16	1.0	4.5	J65LS	12	L02	L03	12 x M12	63.4	71.1	931	1025	23	24 x M36	153	193	140	180
914	Steel	900	PN16	1.6	1.6	J67LS	7	L02	L03	14 x M12	81.3	89.7	1005	1125	25	28 x M36	155	195	140	180
916	Coated Steel	900	PN16	1.6	1.6	J67LS	7	L02	L03	14 x M12	80.8	89.2	1007	1125	25	28 x M36	155	195	140	180
945	Ductile Iron	900	PN16	1.0	5.0	J70LS	14	YF2	YF3	14 x M16	90.8	99.1	1054	1125	25	28 x M36	169	199	160	190
1016	Steel	1000	PN16	1.6	1.6	J71LS	7	YF2	YF3	14 x M16	119.8	128.6	1125	1255	25	28 x M39	169	199	160	190
1019	Coated Steel	1000	PN16	1.6	1.6	J71LS	7	YF2	YF3	14 x M16	118.9	127.7	1129	1255	25	28 x M39	169	199	160	190
1048	Ductile Iron	1000	PN16	1.0	5.0	J71LS	14	YF2	YF3	14 x M16	110.4	119.4	1156	1255	25	28 x M39	169	199	160	190
1118	Steel	1100	PN16	1.6	1.6	J73LS	8	YF2	YF3	16 x M16	129.8	139.5	1227	1355	25	32 x M39	169	199	160	190
1121	Coated Steel	1100	PN16	1.6	1.6	J73LS	8	YF2	YF3	16 x M16	128.7	138.5	1231	1355	25	32 x M39	169	199	160	190
1152	Ductile Iron	1100	PN16	1.0	6.0	J121M	16	A2E	A2H	16 x M16	168.0	180.9	1275	1355	38	32 x M39	182	212	160	190
1219	Steel	1200	PN16	1.6	1.6	J121M	8	A2E	A2H	16 x M16	217.4	230.9	1343	1485	38	32 x M45	182	212	160	190
1222	Coated Steel	1200	PN16	1.6	1.6	J121M	8	A2E	A2H	16 x M16	215.8	229.4	1347	1485	38	32 x M45	182	212	160	190
1255	Ductile Iron	1200	PN16	1.0	6.0	J122M	16	A2E	A2H	16 x M16	197.6	211.5	1378	1485	38	32 x M45	182	212	160	190
1422	Steel	1400	PN16	1.6	3.0	J125M	9	A2E	A2H	18 x M16	248.7	264.4	1546	1685	38	36 x M45	182	212	160	190
1426	Coated Steel	1400	PN16	1.6	3.0	J125M	9	A2E	A2H	18 x M16	246.1	261.9	1550	1685	38	36 x M45	182	212	160	190
1462	Ductile Iron	1400	PN16	1.0	7.0	J125M	18	A2E	A2H	18 x M16	223.3	239.4	1585	1685	38	36 x M45	182	212	160	190
1620	Steel	1600	PN16	3.0	3.0	J127M	Not Rqd.	A2E	A2H	20 x M16	315.9	333.7	1745	1930	38	40 x M52	182	212	160	190
1626	Coated Steel	1600	PN16	3.0	3.0	J127M	Not Rqd.	A2E	A2H	20 x M16	311.3	329.2	1751	1930	38	40 x M52	182	212	160	190
1668	Ductile Iron	1600	PN16	1.0	7.0	J128M	20	A2E	A2H	20 x M16	281.3	299.7	1791	1930	38	40 x M52	182	212	160	190

Every effort has been made to ensure that the information contained in this publication is accurate at the time of publishing. Crane Ltd assumes no responsibility or liability for typographical errors or omissions or for any misinterpretation of the information within the publication and reserves the right to change without notice.

DR10998_01_10_2024_ISSUE 8

Technical Information

Viking Johnson manufacture flange adaptors to any pipe OD and flange drilling. If the product required is not shown in any of our tables please contact Viking Johnson who can provide the relevant information.

Working Pressure Rating

For Water / Wastewater applications in accordance with flange rating.

Gas 6 bar

Vacuum Pressure

Capable of accommodating a vacuum pressure of -0.7 bar

Site Test Pressure

1.5 times working pressure for short duration (2 hours)

End Load Due to Internal Pressure

Dedicated Flange Adaptors DO NOT resist end load due to the internal pressure - adequate external restraint must be provided to prevent pipe pull out from the coupling.

Tie Rods

When using tie rods to provide restraint, depending on the pipe OD & flange drilling the flange adaptor end ring may need to be notched to allow the tie rod to pass over.

The Large Diameter Flange Adaptor Technical Data (BS EN 1092-1 PN16 Drilling) Table provides details on:

- Those products that do not require notching (i.e. there is no interference between the tie rods and end ring) - indicated by "Not Rqd."
- Those products where there is interference between the tie rod and end ring and do require notching, with the number of notches provided as standard indicated.

Materials & Relevant Standards

Flange Body & End Ring

Steel to BS EN10025-2: Grade S275JR

Gaskets: L02/L03/YF2/YF3

Rubber 80 IRHD Moulded Compound to BS EN681-1: Type WA,WC,WG

BS EN682: Type G

(other materials available on request)

Gaskets: A2E/A2H/XSXG

Rubber 70 IRHD Moulded Compound to BS EN681-1: Type WA, WC, WG

BS EN682: Type G

(other materials available on request)

Tie Rod Yield Strength

The number of notches indicated assumes the use of tie rods with a minimum yield strength of 725 N/mm².

If tie rods with a lower yield strength are used, then depending on the working pressure an increased number than that specified in the table may be required; in this situation please advise Viking Johnson of the number of notches and we will accommodate your requirements.

Temperature Rating of Product

EPDM -20°C to +90°C

Nitrile -20°C to +90°C

Other Gasket Grades Contact Viking Johnson.

For use on applications with fluctuating and / or elevated temperatures (> 60°C) may require regular maintenance to re-tighten the bolts and must be included in any maintenance schedule.

Approvals

The following water contact materials used in Large Diameter Dedicated products are approved for use with potable water:-

Rilsan Nylon 11:

- WRAS, DVGW, W270, ACS & KIWA.

EPDM Gaskets:

- WRAS

In addition to the above, Large Diameter Dedicated range as a finished product has KIWA certification verifying that the above products comply with the requirements of the Water Supply (Water Fittings) Regulations for England and Wales 1999, the Water Byelaws 2000, Scotland and the Water Regulations Northern Ireland.

Coatings

Body, Flange & End Ring:

- Rilsan Nylon 11 to WIS 4-52-01 Part 1

Nuts & Studs:

- Sheraplex coated to WIS 4-52-03

Studs

Steel to BS EN ISO898-1: Property Class 4.8

Nuts

Steel to BS4190: Grade 4

Washers

Stainless Steel to BS1449:Part 2: Grade 304S15