

### PN10 Flange Adaptors

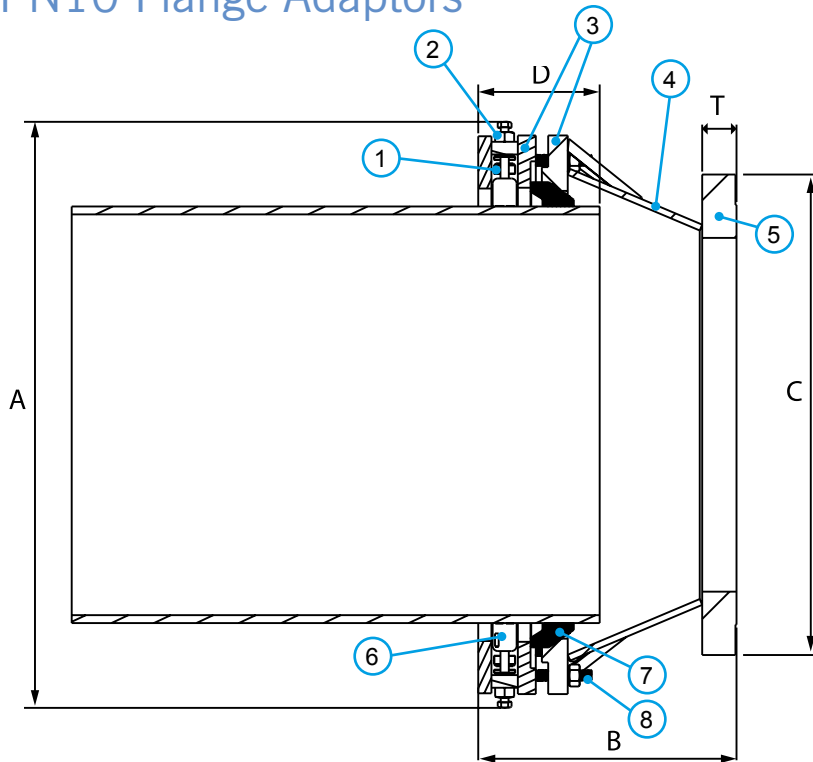

#### Key

- 1 = Square Bush Nut
- 2 = Bolt, Nut & Washer
- 3 = End Ring
- 4 = Centre Sleeve
- 5 = Flange Ring
- 6 = Gripper
- 7 = Gasket
- 8 = Studs



**HAZARD WARNING:** Lifting lugs, where provided, are designed/tested for lifting only the components to which they are attached. Failure to follow these instructions could result in property damage, serious personal injury or death. The maximum safe working load of the lifting eye is equal to the product weight.

### Flange Adaptors

Nom Size	Size Range		Flange Nom Size	Flange Drilling	Insertion Depth (D)		Setting Gap		Dimensions				Fasteners		Weight (kg)
	Min	Max			Min	Max	Min	Max	C	A	B	T	Axial Stud No-size	Radial Bolt No-size	
700	700	735	700	PN10	220	245	265	290	780	1085	710	42	16 x M20	24 x M16	437
700	727	762	700	PN10	220	245	265	290	985	1115	510	50	16 x M20	32 x M16	454
700	750	785	700	PN10	220	245	265	290	895	1135	510	50	16 x M20	24 x M16	455
800	789	824	800	PN10	220	245	275	300	1015	1135	520	56	18 x M20	30 x M16	539
800	825	860	800	PN10	220	245	270	295	1015	1210	515	56	18 x M20	40 x M16	559
800	853	888	800	PN10	220	245	275	300	1015	1240	520	56	18 x M20	30 x M16	559

Flange Drilling - All flanges are drilled to BS EN 1092- part 1 and are flat face flanges

### Connections based on standard pipe OD's\*

Nom Size	Range		Ductile Iron	PE / MOPVC	Steel / FBE Coated Steel	Cast Iron	Asbestos Cement
	Min	Max					
DN700	700	735		710mm	DN700	26" (AB & CD)	26" (AB & CD)
DN700	727	762	DN700			27" (AB & CD)	27" (AB & CD)
DN700	750	785			DN750	28" (AB & CD)	28" (AB & CD)
DN800	789	824		800mm	DN800	30" (AB)	30" (AB)
DN800	825	860	DN800				
DN800	853	888				32" (AB & CD)	32" (AB & CD)

\*The above table is for guidance only, please ensure the OD and material of the pipe is compatible before installation

### Working Pressure & Temperature Ratings

Nominal Size	Gripping Product		Flex Product		Operating Temperature
	Gas	Water	Gas	Water	
DN700	N/A	10 bar	N/A	10 bar	-20 to +60
DN800	N/A	10 bar	N/A	10 bar	

### Pipe Materials



Every effort has been made to ensure that the information contained in this publication is accurate at the time of publishing. Crane Ltd assumes no responsibility or liability for typographical errors or omissions or for any misinterpretation of the information within the publication and reserves the right to change without notice.

### PN10 Flange Adaptors

### Technical Information

#### Working pressure rating:

Water:  
DN700 to DN800 = 10 bar  
Gas:  
Not approved

#### Site test pressure:

1.5 times working pressure

#### Angularity

Flange Adaptor 4°

#### Gripping product suitable for

Ductile iron / PE (PE100, SDR 11 and 17)  
Steel / Cast iron / MOPVC (SDR 33)

#### Flex product suitable for

Ductile Iron / PE (PE100, SDR 11 and 17)  
Steel / Cast Iron / MOPVC / Asbestos Cement

#### Bolt Torque

	Recommended Bolt Torque (Nm) on every bolt				
	Bolt Size	Ductile Iron	PE-100	Steel & Cast Iron	MOPVC
<b>Axial Fastener</b> (For Gasket Engagement)	M20	190-210	190-210	190-210	190-210
<b>Radial Fastener</b> (For Grippers)	M16	175-185	140-150	110-120	95-105

For the full installation details and to ensure correct fitting, please refer to the Ultragrip DN700 DN800 installation instructions.

#### Temperature rating of product

Operating temperature -20°C to +60°C

#### Support liners – PE and MOPVC pipes

A close fit Viking Johnson support liner is required when used on:

- All PE pipes
- MOPVC pipes

#### Use of restrained couplings on exposed pipework

Above ground exposed pipework is subject to both loads from the internal pressure and those from temperature changes / thermal expansion, which can be substantially higher than those from internal pressure and cannot always be safely determined. UltraGrip can be used in above ground applications, where it is not exposed to direct sunlight, and falls within the 40°C operating temperature range (between -20°C and +60°C).

#### Approvals

The following water contact materials used in UltraGrip are approved for use with potable water:-

Rilsan Nylon 11:

- WRAS, AS/NZS 4020, DVGW, W270, ACS & KIWA

Gasket (EPDM):

- WRAS, W270

#### Finished Product:

BS8561; WRc certification verifying that the product complies with BS8561 (Specification for mechanical fittings for use in the repair, connection and renovation of pressurized water supply pipelines — Requirements and test methods).

Polyethylene Pipe Pull Out Performance; WRc certification confirming on PE a Type 2 end load performance (defined in IGN 4-01-02:2017 [N3]) when tested in accordance with the method given in BS EN ISO 3501.

## Materials & Relevant Standards

#### 1) Square Bush Nut

Cast stainless steel to ASTM A487/A487M-21, Grade CA6NM Class A

#### 2) Bolts

Stainless steel to BS EN ISO 3506-1 Grade A4-80

#### 2) Nuts

Stainless steel – BS1449:PT2 ISO 3506-1 Grade A4-80

#### 2) Washers

Stainless steel – BS1449:PT2 ISO 3506-1 Grade A4-50

#### 3) End Rings 4) Centre Sleeve

Mild steel to BS EN10025 Grade S355

#### 5) Flange Ring

S275 Mild Steel to BS EN 10025-2

#### 6) Gripper

Stainless steel (Cast) PH 17-4 H925 to BS EN 10088-1

#### 7) Gasket

EPDM to BS EN 681-1

#### 8) Studs

Stainless steel – BS EN ISO 3506-1 Grade A4-80

#### Coatings

End Rings / Centre Sleeve / Flange:

- Rilsan Nylon 11 (Black)

Bolts:

- Dry Film Lubricant GZ – Silver

Nuts:

- Dry Film Lubricant GZ – Silver

Gripper - None

#### Retention Insert

Nylon 6