

# AquaShield®

Couplings & Flange Adaptors

NEW



AquaShield® - Universal Fittings For Barrier Pipes



## Brownfield Sites

Brownfield sites gained political significance after the UK government set a national target in February 1998 to ensure 60 per cent of all new housing developments were to be built on brownfield land. This land had been previously developed for industrial or commercial purposes and may have also been contaminated owing to its prior use.

Brownfield development is preferable to building on the green belt and has been reinforced as established government planning policy in subsequent years especially with the growing demand to encourage and support sustainable solutions.

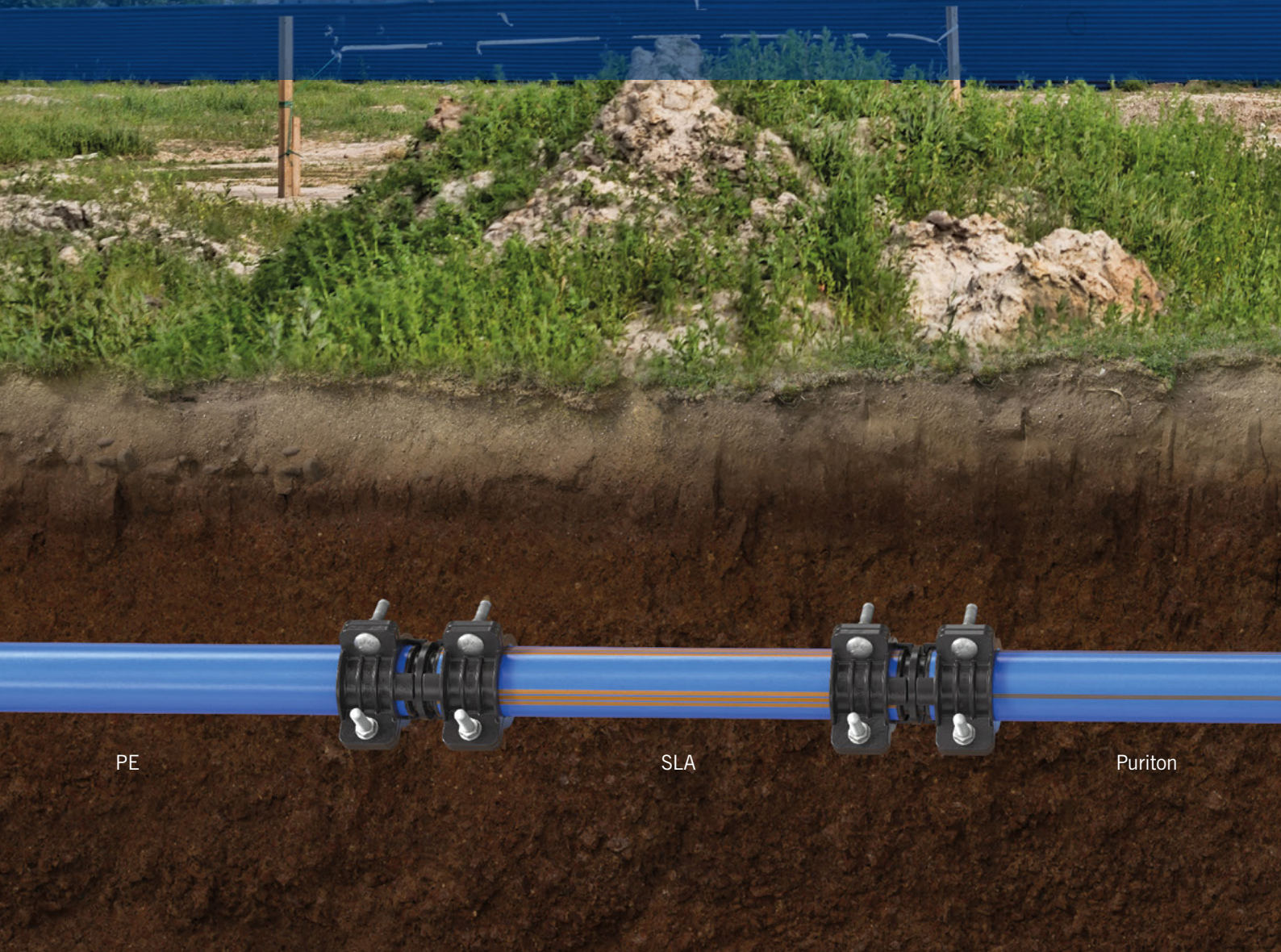

PE

SLA

Puriton



## AquaShield® - Unique Fittings for Barrier Pipe Connections

Consequently, there has been a demand for barrier pipe and the connections required between pipework to protect water supplies for households and businesses from possible contamination.

However, up until now a key unsolved client issue has been that no independently certified solution for joining pipe systems from different manufacturers is available.

And although connections can be made by electrofusion this often involves heavy and expensive equipment and trained operators. **This is where AquaShield® can help.**





### The AquaShield® Solution

AquaShield® is a non-permeable universal fitting, available as a coupling or a flange adaptor to be used on new installations and repairs to connect different barrier pipe systems reliably.

These fittings prevent contaminants entering water networks by sealing the barrier pipe from within while keeping the outer layer of the barrier pipe intact. It can also be used as a transition to a standard PE water network.

AquaShield® is rated to 16 bar working pressure and has a unique gripping mechanism offering WIS 4-24-01 type-1 end load restraint which means the pipe will fail before the fitting.



### AquaShield® Universal Fitting Examples for Barrier Pipes

#### Coupling - Puriton to Puriton



#### Coupling - Protecta-Line to Puriton



#### Coupling - SLA to PE



#### Flange Adaptors - Protecta-Line and PE connection



### Unique Gripping Technology

AquaShield® forms a leak-tight seal without the need for a gasket simply by torquing up the bolts. The spigot profile design ensures a firm and secure connection is made from inside the pipe.

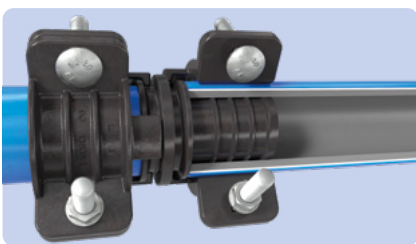

1. Loosen bolts slightly and slide pipe on

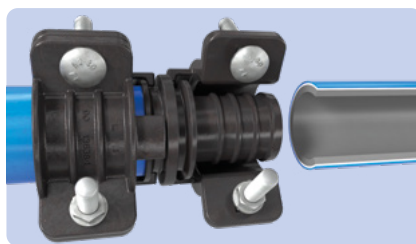

2. Push pipe on to spigot and check is visible in indicator window

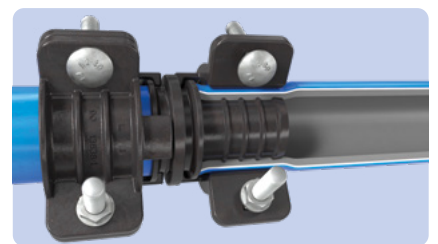

3. Tighten bolts sequentially and incrementally

# Couplings & Flange Adaptors

## Product Design Benefits

AquaShield® is simple to install and comes preassembled with captive and reversible stainless steel bolts, which makes it quick and easy to slide onto the pipe and tighten up with only a single spanner or a wrench. There is no requirement for pipe surface preparation and no need to wrap after installation. Fittings have a 50 year design life expectancy and have been independently tested and approved to BS 8561:2021 and certified by WRc and RINA for permeation against contaminants as per BS 8588:2017 (section 7.7).



Long life Protection  
50 year design life expectancy is assured through accelerated ageing tests that simulates the life cycle of the product.

Fully restrained, Type-1 fitting designed to meet the performance requirements of BS 8561:2021.

Universal fitting that interconnects all major barrier pipe brands including Protecta-Line, Puriton, SLA and PE 100.

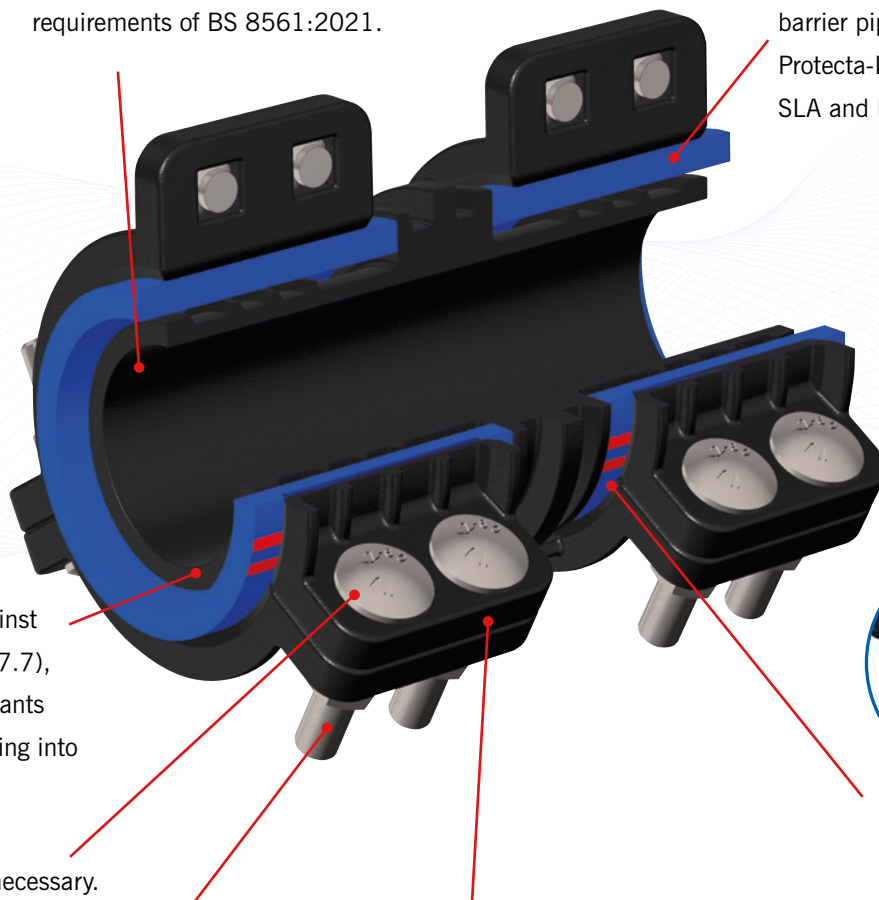

Independently tested against BS 8588:2017 (section 7.7), which prevents contaminants from the ground penetrating into the water supply.

No secondary re-torque necessary.

Stainless steel nuts and bolts coated with dry film lubricant, which provides long term corrosion protection.

As with all Viking Johnson products, AquaShield® utilises Rilsan: a bio coating made from castor oil which is highly protective and environmentally sustainable.



Visual indicator for correct installation.



AquaShield® Flange Adaptor

DR11165\_20\_12\_2022\_V1

## AquaShield® Coupling

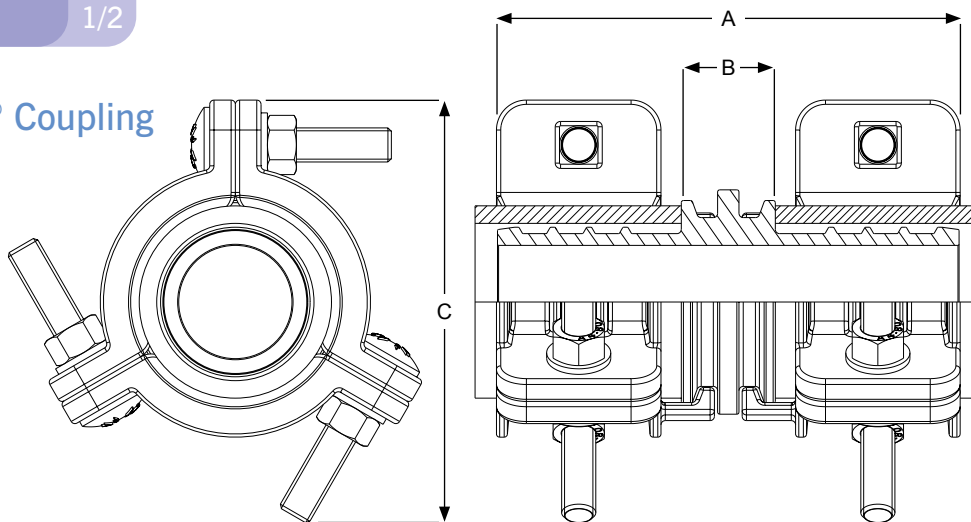

Pipe OD	SDR Rating	Dimensions (mm)			Clamp Band Bolts		Weight (kg)
		A	B	C	No. of Bolts	Bolts size	
90	11	217	45	198	6	M16 x 80	7
90	17	217	45	198	6	M16 x 80	7

## AquaShield® Flange Adaptor

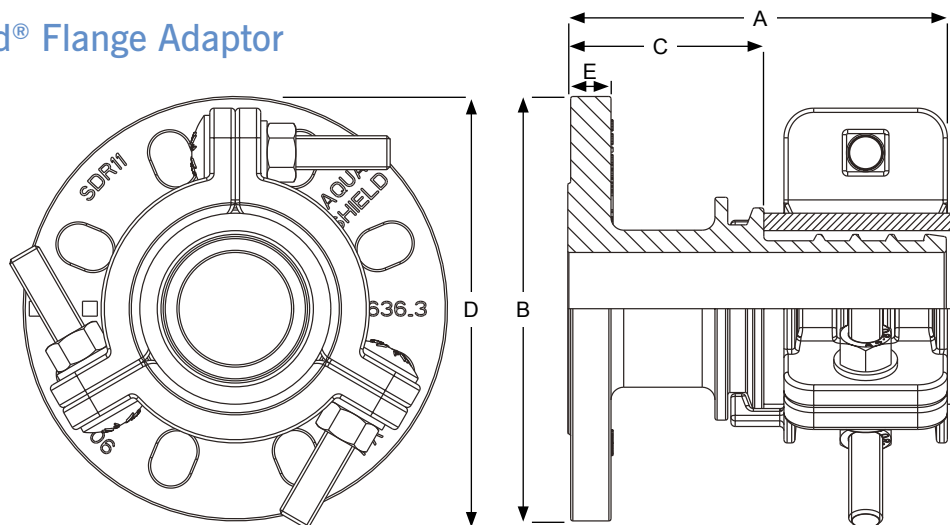

Pipe OD	SDR Rating	Flange Drilling		Dimensions (mm)					Clamp Band Bolts		Weight (kg)
		Nom (DN)	Metric Drilling Specification	A	B	C	D	E	No. of Bolts	Bolts size	
90	11	DN65 / DN80	PN10 / 16	179	200	93	198	20.34	3	M16 x 80	9
90	17	DN65 / DN80	PN10 / 16	179	200	93	198	20.34	3	M16 x 80	9

Every effort has been made to ensure that the information contained in this publication is accurate at the time of publishing. Crane Ltd assumes no responsibility or liability for typographical errors or omissions or for any misinterpretation of the information within the publication and reserves the right to change without notice.

DR11165\_20\_12\_2022\_V1

## Technical Information

### Working Pressure Rating

Water 16 bar

Gas not approved

### Vacuum Pressure

Capable of accommodating a vacuum pressure of -0.8 bar

### Site Test Pressure

1.5 times working pressure for short duration (2 hours)

### Pipe Material

Compatible\* with following barrier pipe materials:-

- GPS Protecta-Line
- Radius Puriton
- Egeplast SLA

In addition, works on standard PE 100 Pipe to BS EN 12001:2011/2012

In all cases the SDR rating must be either 11 or 17.

### Angularity

Not Applicable

### Bolt Torque/Spanner

Torque 200-210Nm on every bolt

Spanner size A/F 24mm

### Temperature Rating of Product

-20°C to +40°C

For optimal installation temperature, please refer to the installation manual.

### End Load Due to Internal Pressure

AquaShield® fully restrained fitting, designed to meet the performance requirements of WIS 4-24-01 Type 1 and BS 8561:2021.

### Approvals

The following water contact materials used in AquaShield® are approved for use with potable water:-

Rilsan Nylon 11:

- WRAS, AS/NZS 4020, DVGW, W270, ACS & KIWA

Permeation test in accordance with BS 8588:2017 (section 7.7) conducted and independently verified by RINA test laboratory.

Verification of compliance with BS 8561:2021 and BS 8588:2017 (section 7.7) by Water Research Centre (WRc).

KIWA UK Reg4 Approval (Pending).

## Materials & Relevant Standards

### Coupling, Flange Adaptor & Clamp Bands

SG Iron to BS EN 1563 Symbol EN-GJS-450-10

### Bolts

Stainless Steel grade A2-70

### Nuts

Stainless Steel grade A4-80

### Coatings:

Cast/Metal Components:

- Rilsan Nylon 11 (Black)

Bolts and Nuts:

- Delta Seal Silver GZ

\* Relevant tests have been conducted and certifications obtained in accordance with BS 8588:2017 (section 7.7) and BS 8561:2021 for the barrier pipe materials listed above.

Every effort has been made to ensure that the information contained in this publication is accurate at the time of publishing. Crane Ltd assumes no responsibility or liability for typographical errors or omissions or for any misinterpretation of the information within the publication and reserves the right to change without notice.



PIONEERS IN PIPE SOLUTIONS

46-48 WILBURY WAY  
HITCHIN, HERTFORDSHIRE  
SG4 0UD. UNITED KINGDOM  
TELEPHONE: +44 (0)1462 443322  
FAX: +44 (0)1462 443311  
EMAIL: info@vikingjohnson.com

www.vikingjohnson.com

DUBAI SALES OFFICE  
CRANE BS&U  
BUILDING 4, OFFICE 901  
THE GALLERIES  
PO BOX 17415  
DOWNTOWN JEBEL ALI  
DUBAI. UAE  
TELEPHONE: +971 4816 5800

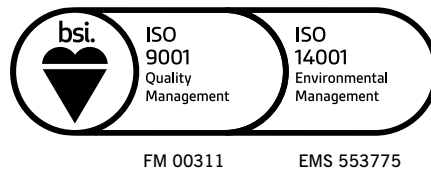

To visit our Video Library go to:  
[www.youtube.com/user/CraneBSU](http://www.youtube.com/user/CraneBSU)

*Every effort has been made to ensure that the information contained in this publication is accurate at the time of publishing. Crane Ltd assumes no responsibility or liability for typographical errors or omissions or for any misinterpretation of the information within the publication and reserves the right to change without notice.*  
*All images used in this marketing literature are the exclusive property of Crane Ltd and copyrighted. These images may not be reproduced, copied, transmitted or manipulated without written permission.*

- Designed and manufactured under quality management systems in accordance with BS EN ISO 9001.
- Environmental Management System accredited to ISO 14001.
- For full terms and conditions, please visit our website.

DR11165\_20\_12\_2022\_V1

