

Dismantling Joints 4" to 40" AWWA (Class D)

Dismantling Joint

(For diameters over 40" contact Viking Johnson)

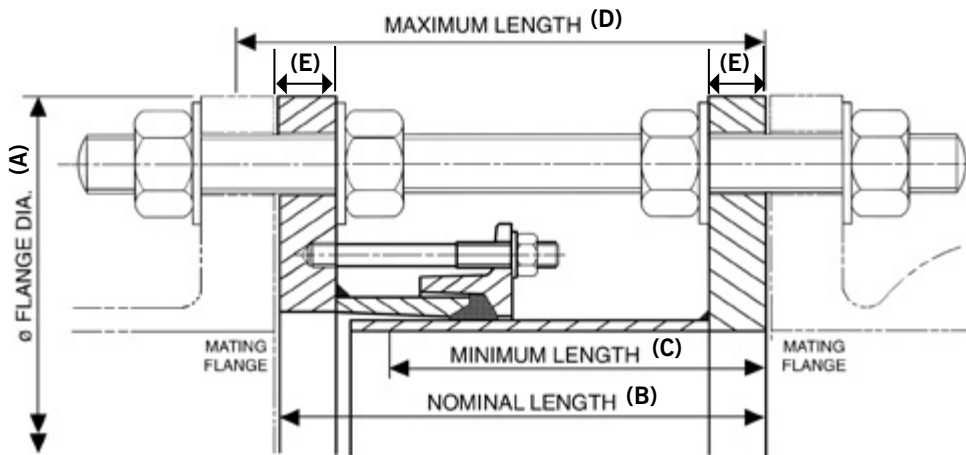

Note: Maximum Longitudinal Adjustment = Maximum Length – Minimum Length

Dismantling Joints (Standard Product)

Table provides details of standard product – for products offering longer flange dimensions and / or increased longitudinal adjustment contact Viking Johnson.

Flange Details				Flange To Flange Details			Tie Rod Details				
Nom	Drilling	Flange Thickness	Flange OD	Nominal Length	Minimum Length	Maximum Length	Tie Rod Dia x Length	H.T Zinc Plated Steel H.T Steel BS4882 Grade MB7 Yield 725N/mm ²		Stainless Steel Class 70 Yield 450N/mm ²	
		E (mm)	A (mm)	B (mm)	C (mm)	D (mm)		No.	Total Weight of DJ (kg)	No.	Total Weight of DJ (kg)
4"	Class D	18	229	187	167	207	5/8" x 11 1/2"	4	14.2	4	14.2
6"	Class D	18	279	187	167	207	3/4" x 12"	4	19.7	4	19.7
8"	Class D	18	343	187	167	207	3/4" x 12"	4	27.5	4	27.5
10"	Class D	18	406	187	167	207	7/8" x 12"	4	35.4	4	35.4
12"	Class D	18	483	187	167	207	7/8" x 12 1/2"	4	48.3	4	48.3
14"	Class D	18	533	295	270	320	1" x 17 1/2"	4	69.3	4	69.3
16"	Class D	18	597	295	270	320	1" x 17 1/2"	4	79.7	4	79.7
18"	Class D	23	635	300	275	325	1 1/8" x 18 1/2"	4	98.3	4	98.3
20"	Class D	23	698	300	275	325	1 1/8" x 18 1/2"	5	115.0	5	115.0
24"	Class D	23	813	300	275	325	1 1/4" x 19"	5	143.0	5	143.0
28"	Class D	23	927	300	275	325	1 1/4" x 19"	7	176.0	7	176.0
30"	Class D	23	984	300	275	325	1 1/4" x 19"	7	189.0	7	189.0
32"	Class D	23	1060	300	275	325	1 1/2" x 20"	7	218.0	7	218.0
36"	Class D	25	1168	307	277	337	1 1/2" x 20 1/2"	8	278.0	8	278.0
40"	Class D	25	1289	307	277	337	1 1/2" x 20 1/2"	9	320.0	9	320.0

Every effort has been made to ensure that the information contained in this publication is accurate at the time of publishing. Crane Ltd assumes no responsibility or liability for typographical errors or omissions or for any misinterpretation of the information within the publication and reserves the right to change without notice.

Dismantling Joints 4" to 40" AWWA (Class D)

Datasheet

2/2

Technical Information

Working Pressure Rating

Water - In accordance with the flange rating
Gas 6 bar

Vacuum Pressure

Capable of accommodating a vacuum pressure of -0.7 bar

Site Test Pressure

1.5 times working pressure for short duration (2 hours)

Angularity

Dismantling joints are in essence double flanged pipe where the flange to flange dimension can be adjusted, and therefore are not able to accommodate any angularity.

Bolt Torque/Spanner

M12; Torque 55-65Nm on every bolt
M16; Torque 95-110Nm on every bolt

Tie rods

Torque is a function of the flange connecting gasket, not supplied by Viking Johnson; consult flange gasket supplier.

Temperature Rating of Product

EPDM -20°C to +90°C
Nitrile -20°C to +90°C

For use on applications with fluctuating and / or elevated temperatures (> 60°C) may require regular maintenance to re-tighten the bolts and must be included in any maintenance schedule.

Approvals

The following water contact materials used in Dismantling Joints are approved for use with potable water:-

Rilsan Nylon 11:

- WRAS, AS/NZS 4020, DVGW, W270, ACS & KIWA

EPDM Gaskets:

- WRAS, AS/NZS 4020

Materials & Relevant Standards

Flange Drilling

ANSI/AWWA C207-01

Fabricated Flange Adaptor Body

Rolled Steel to BS EN 10025-2:
Grade S275

End Rings Options:

- Ductile Iron to BS EN1563:
Symbol EN-GJS-450-10
- Rolled Steel to BS EN 10025-2:
Grade S275

Sleeve Options:

- Steel Tube to BS EN10255:
- Steel Tube to BS EN10216-1:
Grade P265TR1
- Rolled Steel to BS EN 10025-2:
Grade S275
- Rolled Steel to BS EN 10025-2:
Grade S355
(depending on section)

Flange

Rolled Steel to BS EN 10025-2:
Grade S275

Spigot Options:

- Steel Tube to BS EN10255
- Steel Tube to BS EN10216-1:
Grade P265TR1
- Rolled Steel to BS EN 10025-2:
Grade S275

Gaskets

Standard:

- EPDM to BS EN681-1: Type WA

Other gasket grades are available contact Viking Johnson.

Coatings

Flange Adaptor, Spigot & End Ring:

- Rilsan Nylon 11 to
WIS 4-52-01 Part 1

Option 1 Flange Adaptor bolts & Nuts:

- Sheraplex to WIS 4-52-03

Steel Tie Rods/Nuts:

- Zn³ Zinc coated

Tie Rods, Studs, Nuts and Washers

The following two options are as standard variants:-

Option 1: Zinc Plated Steel

Tie Rods

ASTM A193 (Grade B7/MB7) equivalent to BS EN10269:+A1: Name 42CrMo4 (Yield 725N/mm²)

Tie Rod Nuts

ASTM A194 Grade 2H/M2H equivalent to BS EN20898-2: Property Class 8.00

Flange Adaptor Studs

Steel to BS EN ISO898-1: Property Class 4.8

Flange Adaptor Nuts

Steel to BS4190: Grade 4

Flange Adaptor Washers

Stainless Steel to BS1449:Part 2: Grade 304S15

Option 2: Stainless Steel

Tie Rods

Stainless Steel to BS EN3506-1: Grade A4 Property Class 70 (Yield 450N/mm²)

Tie Rod Nuts

Stainless Steel to BS EN3506-2: Grade A4 Property Class 80

Flange Adaptor Studs

Stainless Steel to BS EN ISO 3506-1: grade A4 property class 50

Flange Adaptor Nuts

Stainless Steel to BS EN ISO 3506-2: grade A4 property class 80

Flange Adaptor Washers

Stainless Steel to BS1449: Part 2: Grade 304S15