

Dismantling Joints DN350 to DN1600 (PN40)

Datasheet

1/2

Dismantling Joint

(For diameters over DN1600 contact Viking Johnson)

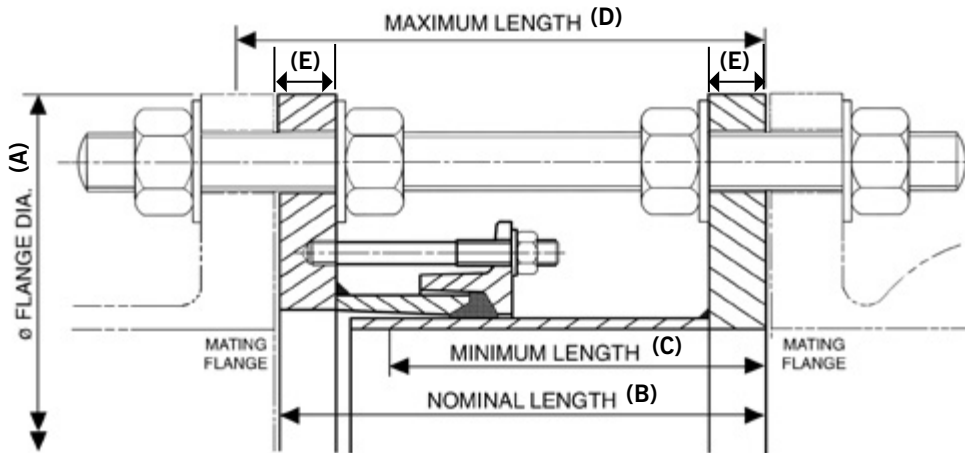

Note: Maximum Longitudinal Adjustment = Maximum Length – Minimum Length

Dismantling Joints (Standard Product)

Table provides details of standard product – for products offering longer flange dimensions and / or increased longitudinal adjustment contact Viking Johnson.

Flange Details		Flange To Flange Details					Tie Rod Details					
Nom	Drilling	Flange Thickness	Flange OD	Nominal Length	Minimum Length	Maximum Length	Steel Tie Rod			Stainless Steel Tie Rod		
		E (mm)	A (mm)	B (mm)	C (mm)	D (mm)	Dia x Length (mm)	No.	Total Weight of DJ (kg)	Dia x Length (mm)	No.	Total Weight of DJ (kg)
350	PN40	25	580	307	277	337	M33 x 520	4	111.0	M33 x 520	4	111.0
400	PN40	25	660	307	277	337	M36 x 540	4	138.0	M36 x 540	4	138.0
450	PN40	25	685	307	277	337	M36 x 550	5	148.0	M36 x 550	5	148.0
500	PN40	25	755	307	277	337	M39 x 570	5	178.0	M39 x 570	6	186.0
550	PN40	38	835	320	290	350	M45 x 600	5	289.0	M45 x 600	5	289.0
600	PN40	38	890	320	290	350	M45 x 620	5	313.0	M45 x 620	6	325.0
650	PN40	38	945	320	290	350	M45 x 630	6	350.0	M45 x 630	8	374.0
700	PN40	38	995	320	290	350	M45 x 640	6	375.0	M45 x 640	8	399.0
800	PN40	38	1140	320	290	350	M52 x 680	6	479.0	M52 x 760	8	544.0
900	PN40	38	1250	320	290	350	M52 x 700	7	570.0	M52 x 780	10	661.0
1000	PN40	38	1360	320	290	350	M52 x 720	8	661.0	M52 x 810	14	826.0
1200	PN40	38	1575	320	290	350	M56 x 780	10	863.0	M56 x 870	16	1,073.0
1400	PN40	60	1795	462	412	512	M56 x 980	14	1,640.0	M56 x 1070	22	1,937.0
1600	PN40	60	2025	462	412	512	M64 x 1040	14	1,988.0	M64 x 1140	20	2,318.0

Note: Stainless steel tie rods cannot accommodate this working pressure so not available.

Every effort has been made to ensure that the information contained in this publication is accurate at the time of publishing. Crane Ltd assumes no responsibility or liability for typographical errors or omissions or for any misinterpretation of the information within the publication and reserves the right to change without notice.

DR10450_03_03_2020_ISSUE 7

Dismantling Joints DN350 to DN1600 (PN40)

Datasheet

2/2

Technical Information

Working Pressure Rating

Water - In accordance with the flange rating
Gas 6 bar

Vacuum Pressure

Capable of accommodating a vacuum pressure of -0.7 bar

Site Test Pressure

1.5 times working pressure for short duration (2 hours)

Angularity

Dismantling joints are in essence double flanged pipe where the flange to flange dimension can be adjusted, and therefore are not able to accommodate any angularity.

Bolt Torque/Spanner

M12; Torque 55-65Nm on every bolt
M16; Torque 95-110Nm on every bolt

Tie rods

Torque is a function of the flange connecting gasket, not supplied by Viking Johnson; consult flange gasket supplier.

Temperature Rating of Product

EPDM -20°C to +90°C
Nitrile -20°C to +90°C

For use on applications with fluctuating and / or elevated temperatures (> 60°C) may require regular maintenance to re-tighten the bolts and must be included in any maintenance schedule.

Approvals

The following water contact materials used in Dismantling Joints are approved for use with potable water:-

Rilsan Nylon 11:

- WRAS, AS/NZS 4020, DVGW, W270, ACS & KIWA

EPDM Gaskets:

- WRAS, AS/NZS 4020

Materials & Relevant Standards

Flange Drilling

BS EN1092-1
(formerly BS4504), ISO7005

Fabricated Flange Adaptor Body

Rolled Steel to BS EN 10025-2:
Grade S275

End Rings & Sleeve Options:

- Rolled Steel to BS EN 10025-2:
Grade S275
- Rolled Steel to BS EN 10025-2:
Grade S355
(depending on section)

Flange

Rolled Steel to BS EN 10025-2:
Grade S275

Spigot Options:

- Steel tube to BS10216-1:
Grade P265TR1
- Rolled steel to BS EN10025-2:
Grade S275

Gaskets

Standard:

- EPDM to BS EN681-1: Type WA
- Other gasket grades are available contact Viking Johnson.

Coatings

Flange Adaptor, Spigot & End Ring:

- Rilsan Nylon 11 to
WIS 4-52-01 Part 1
- Option 1 Flange Adaptor bolts & Nuts:
- Sheraplex to WIS 4-52-03
- Steel Tie Rods/Nuts:
- Zn³ Zinc coated

Tie Rods, Studs, Nuts and Washers

The following two options are as standard variants:-

Option 1: Zinc Plated Steel

Tie Rods

ASTM A193 (Grade B7/MB7) equivalent to BS EN10269:+A1: Name 42CrMo4 (Yield 725N/mm²)

Tie Rod Nuts

ASTM A194 Grade 2H/M2H equivalent to BS EN20898-2: Property Class 8.00

Flange Adaptor Studs

Steel to BS EN ISO898-1: Property Class 4.8

Flange Adaptor Nuts

Steel to BS4190: Grade 4

Flange Adaptor Washers

Stainless Steel to BS1449:Part 2: Grade 304S15

Option 2: Stainless Steel

Tie Rods

Stainless Steel to BS EN3506-1: Grade A4 Property Class 70 (Yield 450N/mm²)

Tie Rod Nuts

Stainless Steel to BS EN3506-2: Grade A4 Property Class 80

Flange Adaptor Studs

Stainless Steel to BS EN ISO 3506-1: grade A4 property class 50

Flange Adaptor Nuts

Stainless Steel to BS EN ISO 3506-2: grade A4 property class 80

Flange Adaptor Washers

Stainless Steel to BS1449: Part 2: Grade 304S15