

# Dismantling Joints DN350 to DN1800 (PN25)

## Dismantling Joint

(For diameters over DN1800 contact Viking Johnson)

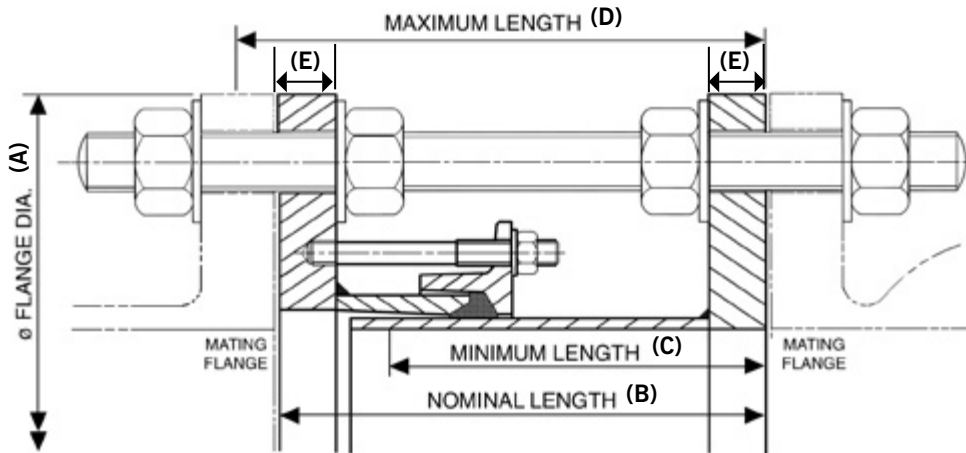

**Note:** Maximum Longitudinal Adjustment = Maximum Length – Minimum Length

## Dismantling Joints (Standard Product)

Table provides details of standard product – for products offering longer flange dimensions and / or increased longitudinal adjustment contact Viking Johnson.

Flange Details		Flange To Flange Details					Tie Rod Details					
Nom	Drilling	Flange Thickness	Flange OD	Nominal Length	Minimum Length	Maximum Length	Steel Tie Rod			Stainless Steel Tie Rod		
		E (mm)	A (mm)	B (mm)	C (mm)	D (mm)	Dia x Length (mm)	No.	Total Weight of DJ (kg)	Dia x Length (mm)	No.	Total Weight of DJ (kg)
350	PN25	25	555	302	277	327	M30 x 480	4	91.1	M30 x 480	4	91.1
400	PN25	25	620	302	277	327	M33 x 490	4	109.0	M33 x 490	4	109.0
450	PN25	25	670	302	277	327	M33 x 500	5	122.0	M33 x 500	5	122.0
500	PN25	25	730	302	277	327	M33 x 510	5	137.0	M33 x 510	5	137.0
550	PN25	25	785	302	277	327	M36 x 530	5	155.0	M36 x 530	5	155.0
600	PN25	25	845	302	277	327	M36 x 540	5	170.0	M36 x 540	6	177.0
650	PN25	25	895	307	277	337	M36 x 550	6	199.0	M36 x 550	8	211.0
700	PN25	25	960	302	277	327	M39 x 570	6	212.0	M39 x 570	8	227.0
800	PN25	25	1085	307	277	337	M45 x 630	6	279.0	M45 x 630	8	302.0
900	PN25	25	1185	307	277	337	M45 x 630	7	317.0	M45 x 630	10	350.0
1000	PN25	38	1320	320	290	350	M52 x 660	7	520.0	M52 x 740	8	567.0
1200	PN25	38	1530	320	290	350	M52 x 690	8	637.0	M52 x 770	12	724.0
1400	PN25	60	1755	462	412	512	M56 x 890	9	1,181.0	M56 x 980	14	1,369.0
1600	PN25	60	1975	462	412	512	M56 x 920	10	1,514.0	M56 x 1010	16	1,740.0
1800	PN25	60	2185	462	412	512	M64 x 970	11	1,855.0	M64 x 1075	16	1,970.0

Every effort has been made to ensure that the information contained in this publication is accurate at the time of publishing. Crane Ltd assumes no responsibility or liability for typographical errors or omissions or for any misinterpretation of the information within the publication and reserves the right to change without notice.

# Dismantling Joints DN350 to DN1800 (PN25)

Datasheet

2/2

## Technical Information

### Working Pressure Rating

Water - In accordance with the flange rating  
Gas 6 bar

### Vacuum Pressure

Capable of accommodating a vacuum pressure of -0.7 bar

### Site Test Pressure

1.5 times working pressure for short duration (2 hours)

### Angularity

Dismantling joints are in essence double flanged pipe where the flange to flange dimension can be adjusted, and therefore are not able to accommodate any angularity.

### Bolt Torque/Spanner

M12; Torque 55-65Nm on every bolt  
M16; Torque 95-110Nm on every bolt

### Tie rods

Torque is a function of the flange connecting gasket, not supplied by Viking Johnson; consult flange gasket supplier.

### Temperature Rating of Product

EPDM -20°C to +90°C  
Nitrile -20°C to +90°C

For use on applications with fluctuating and / or elevated temperatures (> 60°C) may require regular maintenance to re-tighten the bolts and must be included in any maintenance schedule.

### Approvals

The following water contact materials used in Dismantling Joints are approved for use with potable water:-

Rilsan Nylon 11:

- WRAS, AS/NZS 4020, DVGW, W270, ACS & KIWA

EPDM Gaskets:

- WRAS, AS/NZS 4020

## Materials & Relevant Standards

### Flange Drilling

BS EN1092-1  
(formerly BS4504), ISO7005

### Fabricated Flange Adaptor Body

Rolled Steel to BS EN 10025-2:  
Grade S275

### End Rings & Sleeve Options

- Rolled Steel to BS EN 10025-2:  
Grade S275
- Rolled Steel to BS EN 10025-2:  
Grade S355  
(depending on section)

### Flange

Rolled Steel to BS EN 10025-2:  
Grade S275

### Spigot Options:

- Steel Tube to BS10216-1:  
Grade P265TR1
- Rolled steel to BS EN10025-2:  
Grade S275

### Gaskets

Standard:

- EPDM to BS EN681-1: Type WA
- Other gasket grades are available contact Viking Johnson.

### Coatings

Flange Adaptor, Spigot & End Ring:

- Rilsan Nylon 11 to  
WIS 4-52-01 Part 1
- Option 1 Flange Adaptor bolts & Nuts:
- Sheraplex to WIS 4-52-03
- Steel Tie Rods/Nuts:
- Zn<sup>3</sup> Zinc coated

### Tie Rods, Studs, Nuts and Washers

The following two options are as standard variants:-

#### Option 1: Zinc Plated Steel

##### Tie Rods

ASTM A193 (Grade B7/MB7) equivalent to BS EN10269:+A1: Name 42CrMo4 (Yield 725N/mm<sup>2</sup>)

##### Tie Rod Nuts

ASTM A194 Grade 2H/M2H equivalent to BS EN20898-2: Property Class 8.00

##### Flange Adaptor Studs

Steel to BS EN ISO898-1: Property Class 4.8

##### Flange Adaptor Nuts

Steel to BS4190: Grade 4

##### Flange Adaptor Washers

Stainless Steel to BS1449:Part 2: Grade 304S15

#### Option 2: Stainless Steel

##### Tie Rods

Stainless Steel to BS EN3506-1: Grade A4 Property Class 70 (Yield 450N/mm<sup>2</sup>)

##### Tie Rod Nuts

Stainless Steel to BS EN3506-2: Grade A4 Property Class 80

##### Flange Adaptor Studs

Stainless Steel to BS EN ISO 3506-1: grade A4 property class 50

##### Flange Adaptor Nuts

Stainless Steel to BS EN ISO 3506-2: grade A4 property class 80

##### Flange Adaptor Washers

Stainless Steel to BS1449: Part 2: Grade 304S15