

Robust

# MegaFit

Couplings & Flange Adaptors  
Advanced Mechanical Jointing Technology



PIONEERS IN PIPE SOLUTIONS

CRANE

BUILDING SERVICES & UTILITIES



# Universal Pipe Fittings

The MegaFit range of universal pipe fittings represent the very latest in mechanical pipe coupling technology, with products designed to connect plain ended pipes of the same nominal bore, with same or different outside diameters. One coupling is able to connect steel, ductile iron, uPVC, cast iron and asbestos cement pipes, thereby reducing stocks.

### Simplifies Stock-holding & Installation

MegaFit products are designed for use in repair situations where the exact outside diameter of the pipes are unknown. An OD tolerance range of up to 34mm is offered, which has the effect of reducing stockholding, down to one size per nominal diameter, also simplifies installation.

### Simple, Reliable Seal

The MegaFit range design incorporates end rings which are designed to enclose the gasket. The unique 'slide easy' gasket provides maximum sealing pressure, even on scored, pitted and corroded pipe surfaces through its distinctive circumferential ribs offering a simple installation and guaranteed seal.

### Approved Quality

The MegaFit product range includes couplings and flange adaptors, which are available from DN50 (2") to DN300 (12"). All models are designed and manufactured under quality management systems to BS EN ISO 9001 and have been tested by Viking Johnson's comprehensive in-house research facilities and also conform to the American Water Works Association specification AWWA/ANSI C.219 for bolted couplings.



MegaFit Coupling

MegaDaptor Flange Adaptor

MegaFit Coupling

### Pipe Materials



# MegaFit Couplings and Flange Adaptors

## Product Design Benefits

### Guaranteed Sealing

The unique, 'slide easy' gasket provides maximum sealing pressure, even on scored, pitted and corroded pipe surfaces through its distinctive circumferential ribs.



### Excellent Corrosion Protection

Metal components are coated with Rilsan Nylon 11 which is WRAS approved for use with potable water. The nuts and bolts are Sheraplex coated to WIS 4-52-03, offering long term protection to corrosion, impact and abrasion for continued reliable performance.

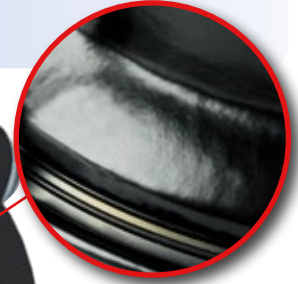

### User Friendly

The MegaFit range is supplied with captive bolts, meaning that the nuts need only to be tightened, with a torque wrench, at one end, saving time and simplifying installation.

### Simple to Fit

MegaFit includes an extended centre sleeve as standard to aid installation it allows for greater cutting tolerances and greater pipe insertion depths - sealing beyond corrosion damaged pipe ends.



## Customer Benefits

- ▶ The MegaFit range is suitable for water and gas applications. Following extensive tests, the products can be guaranteed for a working pressure of 16 bar for water applications (test pressure 24 bar) and 6 bar for gas (test pressure 9 bar).
- ▶ With up to 34mm tolerance on the pipe OD, each product fits a range of pipe diameters and materials. It reduces the need for expensive and time consuming trial holes, reduces stock holding and increases stock turn. In all MegaFit is adaptable and economic solution to most pipe connections.

- ▶ For the discerning customer, the MegaFit range offers an extended sealing face, greater than other wide tolerance models. M16 bolts on DN100 models and above ensure a complete robust solution.
- ▶ MegaFit couplings accommodate angular deflection between pipes of up to 8° for couplings and 4° for flange adaptors, allowing for ease of installation and for pipeline movement such as ground settlement. This angular deflection can be utilised to lay pipelines to long radius curves, without the need for special fittings, saving both time and cost.

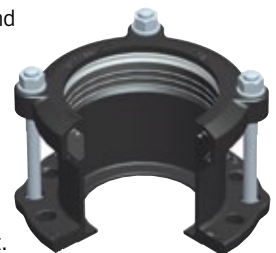

# MegaFit Couplings

Datasheet

1/2

## Coupling

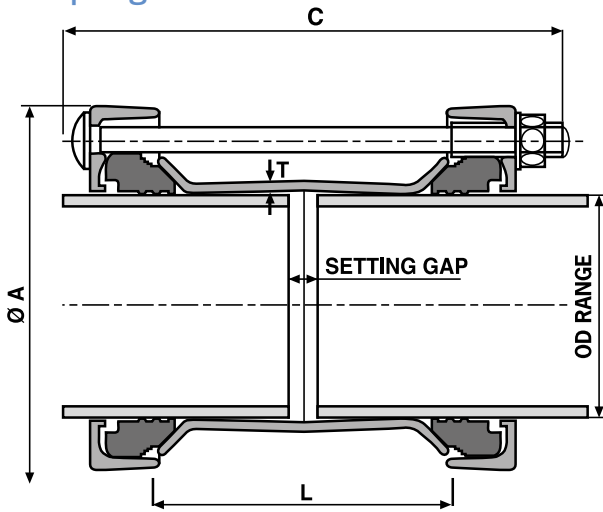

### Key

- A = End Ring Diameter
- C = Overall Length
- L = Sleeve Length
- T = Sleeve Thickness

## MegaFit Couplings

DN	OD Range		Bolts No.-Dia x Length	A (mm)	C (mm)	Sleeve Length x Thickness L x T (mm)	Setting Gap		Gasket Mould No.	Weight (kg)
	Min (mm)	Max (mm)					Min (mm)	Max (mm)		
50	43.5	63.5	4-M12 x 235	151	242	144 x 5	18	60	6010	4.5
65	63.0	83.7	4-M12 x 235	171	242	144 x 5	18	60	6011	5.2
80	85.7	107.0	4-M12 x 260	192	267	170 x 5	18	100	6012	6.3
100	107.2	133.2	4-M16 x 290	231	300	180 x 5	18	110	6013	9.0
125	132.2	160.2	4-M16 x 290	265	300	180 x 5.5	18	110	6014	11.3
150	158.2	192.2	4-M16 x 340	308	350	213 x 5.5	18	130	6015	15.4
175	192.2	226.9	4-M16 x 340	344	350	215 x 7	18	130	6030	21.7
200	218.1	252.1	4-M16 x 340	369	350	220 x 8	18	135	6016	24.3
250	266.2	300.2	6-M16 x 420	417	430	300 x 8	18	215	6017	34.7
300	315.0	349.0	6-M16 x 420	466	430	300 x 8	18	215	6018	39.4

\* Materials of construction at the discretion of Viking Johnson. Viking Johnson reserves the right to modify the details in this publication as products and specifications are updated and improved.

Every effort has been made to ensure that the information contained in this publication is accurate at the time of publishing. Crane Ltd assumes no responsibility or liability for typographical errors or omissions or for any misinterpretation of the information within the publication and reserves the right to change without notice.

DR8550\_03\_2020\_ISSUE 6

## Technical Information

### Working Pressure Rating

Water 16 bar

Gas 6 bar

### Vacuum Pressure

Capable of accommodating a vacuum pressure of -0.7 bar

### Site Test Pressure

1.5 times working pressure for short duration (2 hours)

### Angularity

Couplings 8°

The above are for when the product is on maximum pipe outside diameters; can achieve larger ones with smaller pipe diameters.

### Bolt Torque/Spanner

M12; Torque 55-65Nm on every bolt

M16; Torque 95-110Nm on every bolt

### Temperature Rating of Product

EPDM -20°C to +90°C

Nitrile -20°C to +90°C

For use on applications with fluctuating and / or elevated temperatures (> 60°C) may require regular maintenance to re-tighten the bolts and must be included in any maintenance schedule.

### End Load Due to Internal Pressure

MegaFit DOES NOT resist end load due to the internal pressure - adequate external restraint must be provided to prevent pipe pull out.

### Approvals

The following water contact materials used in MegaFit are approved for use with potable water:-

Rilsan Nylon 11:

- WRAS, AS/NZS 4020, DVGW, W270, ACS & KIWA

EPDM Gaskets:

- WRAS

## Materials & Relevant Standards

### Sleeve\*

SG ductile iron BS EN 1563, EN GJS-450-10

### End Rings\*

SG ductile iron BS EN 1563, EN GJS-450-10

### Coatings

Centre Sleeve & End Rings:

- Rilsan Nylon 11 to WIS 4-52-01 Part 1

Bolts & Nuts:

- Sheraplex to WIS 4-52-03

### Gasket

EPDM compound Grade 'E' to BS EN 681-1 WRAS approved

Nitrile compound to DIN 3535-3

### Bolts

Steel to BS EN ISO 898 Property Class Grade 8.8 equivalent  
DIN 267 - Part 3:Class 8.8

### Nuts

Steel to BS EN20898-2 Property Class 8.0

### Washers

Stainless Steel to BS 1449:Pt2 grade 304 S15

\* Materials of construction at the discretion of Viking Johnson. Viking Johnson reserves the right to modify the details in this publication as products and specifications are updated and improved.

Every effort has been made to ensure that the information contained in this publication is accurate at the time of publishing. Crane Ltd assumes no responsibility or liability for typographical errors or omissions or for any misinterpretation of the information within the publication and reserves the right to change without notice.



# MegaDaptor Flange Adaptors

Datasheet 1/2

## Flange Adaptor Type 1

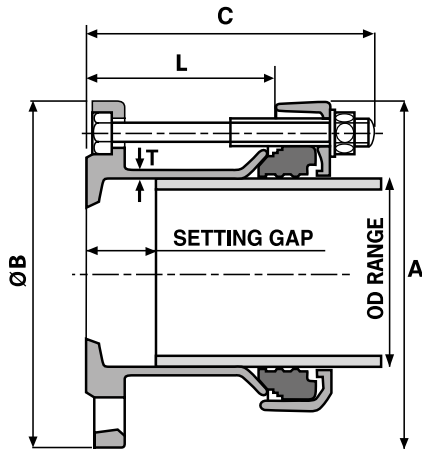

## Flange Adaptor Type 2

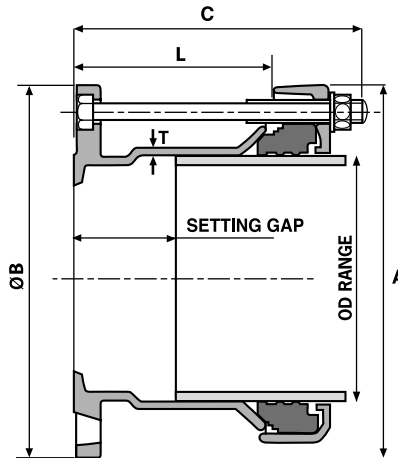

### Key

- A = End Ring Diameter
- B = Flange Diameter
- C = Overall Length
- L = Sleeve Length
- T = Sleeve Thickness

Flange adaptors designed to join pipes of various materials and outside diameters to flanges of the same nominal size\*.

## MegaDaptor Flange Adaptors

DN	OD Range (mm)		Flange Nominal	Flange Drilling	Flange Thickness (mm)	Bolts No.-Dia x Length	A (mm)	B (mm)	C (mm)	Sleeve Length x Thickness (L) x (T)	Setting Gap (mm)		Type	Gasket Mould No.	Weight (kg)
	Min	Max									Min	Max			
50	43.5	63.5	50	PN10/PN16	17.0	4-M12 x 125	151	167	131	80 x 6	25	35	1	6010	4.4
65	63.0	83.7	65	PN10/PN16	17.0	4-M12 x 125	171	185	132	80 x 6	25	35	1	6011	5.1
80	85.7	107.0	80	PN10/PN16	17.0	4-M12 x 145	192	200	154	100 x 6	30	60	1	6012	5.8
100	107.2	133.2	100	PN10/PN16	18.0	4-M16 x 180	231	234	191	130 x 6	57	85	2	6013	8.6
125	132.2	160.2	125	PN10/PN16	18.0	4-M16 x 160	265	268	171	111 x 6	28	65	1	6014	9.8
150	158.2	192.2	150	PN10/PN16	18.0	4-M16 x 210	303	317	220	150 x 6	70	100	2	6015	14.17
175*	192.2	226.9	200	PN10/PN16	18.0	4-M16 x 190	344	344	201	132 x 7	25	80	1	6030	17.2
200	218.1	252.1	200	PN10/PN16	18.0	4-M16 x 230	369	374	241	180 x 7	75	130	2	6016	20.4
250	266.2	300.2	250	PN10/PN16	20.0	6-M16 x 270	417	424	281	212 x 7	80	160	2	6017	27.5
300	315.0	349.0	300	PN10/PN16	21.5	6-M16 x 270	466	472	281	211 x 8	80	160	2	6018	34.3

\*DN175 MegaDaptor supplied with DN200 flange.

\* Materials of construction at the discretion of Viking Johnson. Viking Johnson reserves the right to modify the details in this publication as products and specifications are updated and improved.

Every effort has been made to ensure that the information contained in this publication is accurate at the time of publishing. Crane Ltd assumes no responsibility or liability for typographical errors or omissions or for any misinterpretation of the information within the publication and reserves the right to change without notice.

## Technical Information

### Working Pressure Rating

Water 16 bar

Gas 6 bar

### Vacuum Pressure

Capable of accommodating a vacuum pressure of -0.7 bar

### Site Test Pressure

1.5 times working pressure for short duration (2 hours)

### Angularity

Flange Adaptors 4°

The above are for when the product is on maximum pipe outside diameters; can achieve larger ones with smaller pipe diameters.

### Bolt Torque/Spanner

M12; Torque 55-65Nm on every bolt

M16; Torque 95-110Nm on every bolt

### Temperature Rating of Product

EPDM -20°C to +90°C

Nitrile -20°C to +90°C

For use on applications with fluctuating and / or elevated temperatures (> 60°C) may require regular maintenance to re-tighten the bolts and must be included in any maintenance schedule.

### End Load Due to Internal Pressure

MegaFit DOES NOT resist end load due to the internal pressure - adequate external restraint must be provided to prevent pipe pull out.

### Approvals

The following water contact materials used in MegaFit are approved for use with potable water:-

Rilsan Nylon 11:

- WRAS, AS/NZS 4020, DVGW, W270, ACS & KIWA

EPDM Gaskets:

- WRAS

## Materials & Relevant Standards

### Flange Adaptor Body\*

SG ductile iron BS EN 1563, EN GJS-450-10

### End Ring\*

SG ductile iron BS EN 1563, EN GJS-450-10

### Coatings

Adaptor Body & End Ring:

- Rilsan Nylon 11 to WIS 4-52-01 Part 1

Bolts & Nuts:

- Sheraplex to WIS 4-52-03

### Gasket

EPDM compound Grade 'E' to BS EN 681-1 WRAS approved

Nitrile compound to DIN 3535-3

### Bolts

Steel to BS EN ISO 898 Property Class Grade 8.8 equivalent DIN 267 - Part 3:Class 8.8

### Nuts

Steel to BS EN20898-2 Property Class 8.0

### Washers

Stainless Steel to BS 1449:Pt2 grade 304 S15

\* Materials of construction at the discretion of Viking Johnson. Viking Johnson reserves the right to modify the details in this publication as products and specifications are updated and improved.

Every effort has been made to ensure that the information contained in this publication is accurate at the time of publishing. Crane Ltd assumes no responsibility or liability for typographical errors or omissions or for any misinterpretation of the information within the publication and reserves the right to change without notice.



Germany - Bielefeld

# Replacement of Old Cast Iron Service Pipe

MegaFit Flange Adaptors - DN300

## Project

A DN300 gas main pipeline was cut and a screwed ductile iron tee was installed to build a new service line connected by two MegaFit flange adaptors.

## Client

Stadtwerke Bielefeld

## Distributor

Friatec AG, Mannheim



Crane BS&U are solely the provider of products and have no direct influence on, or take any responsibility for any working practices employed or depicted in the images enclosed to install such products.



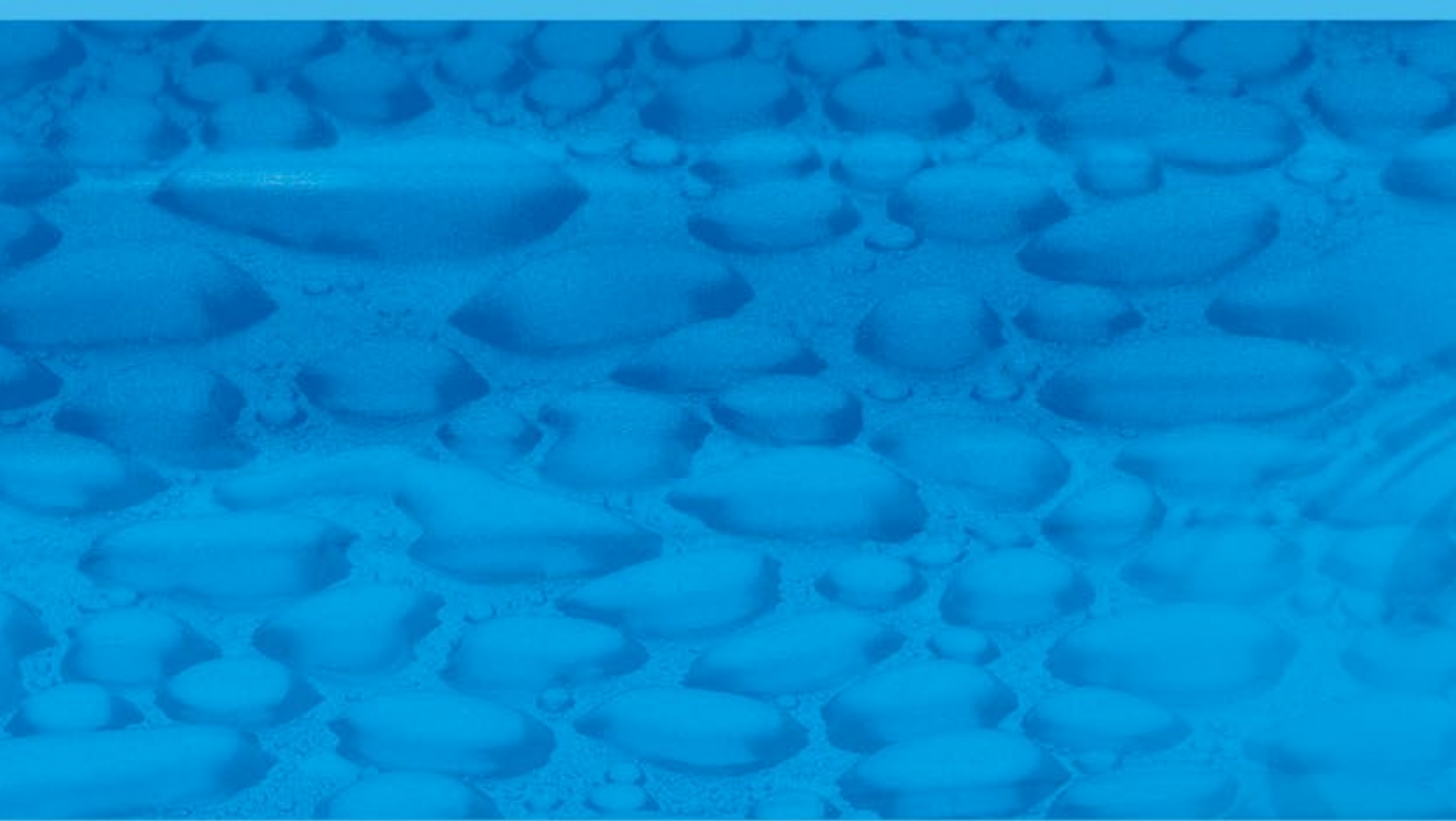

46-48 WILBURY WAY  
HITCHIN, HERTFORDSHIRE  
SG4 0UD. UNITED KINGDOM  
TELEPHONE: +44 (0)1462 443322  
FAX: +44 (0)1462 443311  
EMAIL: info@vikingjohnson.com

[www.vikingjohnson.com](http://www.vikingjohnson.com)

DUBAI SALES OFFICE  
CRANE BS&U  
BUILDING 4, OFFICE 901  
THE GALLERIES  
PO BOX 17415  
DOWNTOWN JEBEL ALI  
DUBAI. UAE  
TELEPHONE: +971 4816 5800



FM 00311

EMS 553775



To visit our Video Library go to:  
[www.youtube.com/user/CraneBSU](http://www.youtube.com/user/CraneBSU)

- Designed and manufactured under quality management systems in accordance with BS EN ISO 9001.
- Environmental Management System accredited to ISO 14001.
- For full terms and conditions, please visit our website.

*Every effort has been made to ensure that the information contained in this publication is accurate at the time of publishing. Crane Ltd assumes no responsibility or liability for typographical errors or omissions or for any misinterpretation of the information within the publication and reserves the right to change without notice.*

DR9560\_03\_2020\_ISSUE 6

PIONEERS IN PIPE SOLUTIONS



[www.cranesbu.com](http://www.cranesbu.com)

