

# Next Generation UltraGrip Reducing Couplings

Datasheet 1/2

## Reducing Coupling

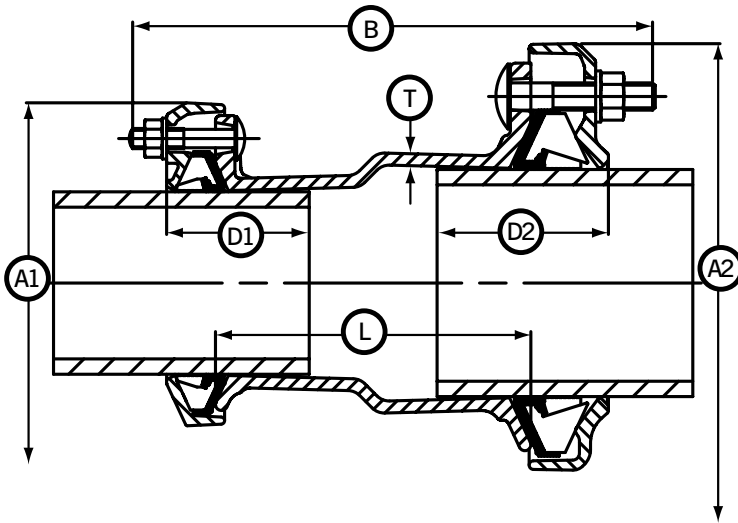

## UltraGrip Reducing Couplings

Nom Size		Size Range				Insertion Depth				Dimensions					Bolts				Weight (kg)
Small End	Large End	Small End		Large End		Small End (D1)		Large End (D2)		Overall		Sleeve			Small End		Large End		
		Min	Max	Min	Max	Min	Max	Min	Max	A1	A2	B	L	T	Size	Type	Size	Type	
32	40	36.0	46.0	43.5	63.5	65	95	65	95	153	168	266	150	5.0	3-M12 x 70	CSX	3-M12 x 70	CSX	5.16
80	100	85.7	107.0	107.0	133.2	65	95	90	125	212	280	325	185	7.5	3-M12 x 70	HRH	3-M16 x 93	CSX	11.42
100	125	107.0	133.2	132.2	160.2	90	125	90	115	280	305	352	190	7.5	3-M16 x 93	CSX	3-M16 x 93	CSX	14.97
100	150	107.0	133.2	158.2	192.2	90	115	90	135	280	339	375	216	7.5	3-M16 x 93	CSX	4-M16 x 93	CSX	17.94
125	150	132.2	160.2	158.2	192.2	90	115	90	135	305	339	366	207	7.5	3-M16 x 93	CSX	4-M16 x 93	CSX	18.37
150	175	158.2	192.2	192.2	226.9	90	125	125	165	339	403	393	220	7.0	4-M16 x 93	CSX	5-M16 x 93	CSX	27.25
175	200	192.2	226.9	218.1	256.0	125	155	125	165	403	432	393	220	7.0	5-M16 x 93	CSX	5-M16 x 93	CSX	34.78
200	250	218.1	256.0	266.0	310.0	125	165	125	165	432	476	479	280	7.0	5-M16 x 93	CSX	6-M16 x 120	CSX	44.59
250	300	266.0	310.0	315.0	356.0	125	165	125	200	476	522	524	300	9.0	6-M16 x 120	CSX	8-M16 x 120	CSX	58.43
400	450	398.0	442.0	448.0	492.0	125	200	125	200	623	713	575	330	7.5	10-M16 x 120	CDX	12-M16 x 140	HRH	117.82
500	500	498.0	552.0	558.0	608.0	140	215	140	215	803	860	595	330	7.5	9-M20 x 150	HRH	9-M20 x 150	HRH	167.21
600	600	604.0	648.0	676.0	726.0	195	255	195	255	900	975	595	330	7.5	10-M20 x 150	HRH	10-M20 x 150	HRH	259.03

## Working Pressure & Temperature Ratings

Nominal Size	Gripping Product		Flex Product		Operating Temperature
	Gas	Water	Gas	Water	
DN40 to DN300	5 bar	16 bar	5 bar	16 bar	-20°C to +30°C
DN350 to DN400	5 bar	10 bar	5 bar	10 bar	
DN450 to DN600	N/A	10 bar	N/A	10 bar	

### Notes:

- 1) Site Test Pressure – 1.5 times working pressure.
- 2) Factory Test Pressure – The minimum requirement in European Standards is 1.5 times working pressure plus 5 bar (e.g. 29 bar for 16 bar working pressure).
- 3) All water contact components are approved for use with Potable Water.

Bolt Torque	
	Nm
<b>M12</b>	55 - 70
<b>M16</b>	95 - 120
<b>M20</b>	210 - 230

Every effort has been made to ensure that the information contained in this publication is accurate at the time of publishing. Crane Ltd assumes no responsibility or liability for typographical errors or omissions or for any misinterpretation of the information within the publication and reserves the right to change without notice.

# Next Generation UltraGrip Reducing Couplings

Datasheet

2/2

## Technical Information

### Gripping product suitable for

Steel / Ductile iron / Grey cast iron / PE / PVC

### Flex product suitable for

Steel / Ductile iron / Grey cast iron / PVC / Asbestos cement

### Angularity

Reducing Coupling 8°

### Support liners – PE and PVC pipes

A close fit support liner is required when used on:

- ▶ All PE pipes
- ▶ Thin walled PVC pipes

When used on thick walled PVC pipes a support liner is not required. Please contact Viking Johnson for further details.

### Use of restrained couplings on exposed pipework

Above ground exposed pipework is subject to both loads from the internal pressure and those from temperature changes / thermal expansion, which can be substantially higher than those from internal pressure and cannot always be safely determined. For this reason it is recommended that the use of UltraGrip be restricted to buried pipelines, valve chambers and above ground indoor applications and not exposed to direct sunlight or excessive temperature changes (e.g. pump houses).

### Approvals

The following water contact materials used in UltraGrip are approved for use with potable water:-

Rilsan Nylon 11:

- ▶ WRAS, KIWA, AS/NZS 4020

Gasket (EPDM):

- ▶ WRAS, KTW, DVGW, W270, KIWA & AS/NZS 4020

In addition to the above, UltraGrip range as a finished product has KIWA certification verifying that the above products comply with the requirements of the Water Supply (Water Fittings) Regulations for England and Wales 1999, the Water Byelaws 2000, Scotland and the Water Regulations Northern Ireland.

Gasket (Nitrile):

- ▶ DVGW Approved

DN40 to DN600 UltraGrip has been independently tested by BSI to confirm it meets the requirements of BS EN 14525 (VC 673979).

## Materials & Relevant Standards

### End Rings & Centre Sleeve

S.G. Iron to BS EN 1563 Symbol EN-GJS-450-10

### Gasket

EPDM Compound Grade E to BS EN 681-1

Nitrile Compound to Grade G BS EN 682, Type G

### Gripper & Carrier

Acetal Copolymer Grade M25 or equivalent

### Coatings

Cast/Metal Components:

- ▶ Rilsan Nylon 11 (Black)

Bolts:

- ▶ Gleitmo 900 (Dry Film Lubricant)

Nuts:

- ▶ Geomet 500

### Bolts

Standard - Stainless steel to BS EN 3506-1 Grade A2 Property Class 80 or 70

Option - Stainless steel to BS EN ISO 3506-1 Grade A4 Property Class 50

### Nuts

Stainless Steel to BS EN 3506-2 Grade A4 Property Class 80

### Washers

Stainless steel – BS1449:PT2 Grade 304 S15

### Grit to Gripper

Corundum - aluminium oxide with a chemical composition of  $Al_2O_3$  and a hexagonal crystal structure (rock-forming mineral that is found in igneous, metamorphic, and sedimentary rocks).

Every effort has been made to ensure that the information contained in this publication is accurate at the time of publishing. Crane Ltd assumes no responsibility or liability for typographical errors or omissions or for any misinterpretation of the information within the publication and reserves the right to change without notice.