

AquaFast Large Diameter Flange Adaptors 355mm to 450mm

Datasheet 1/2

Flange Adaptor

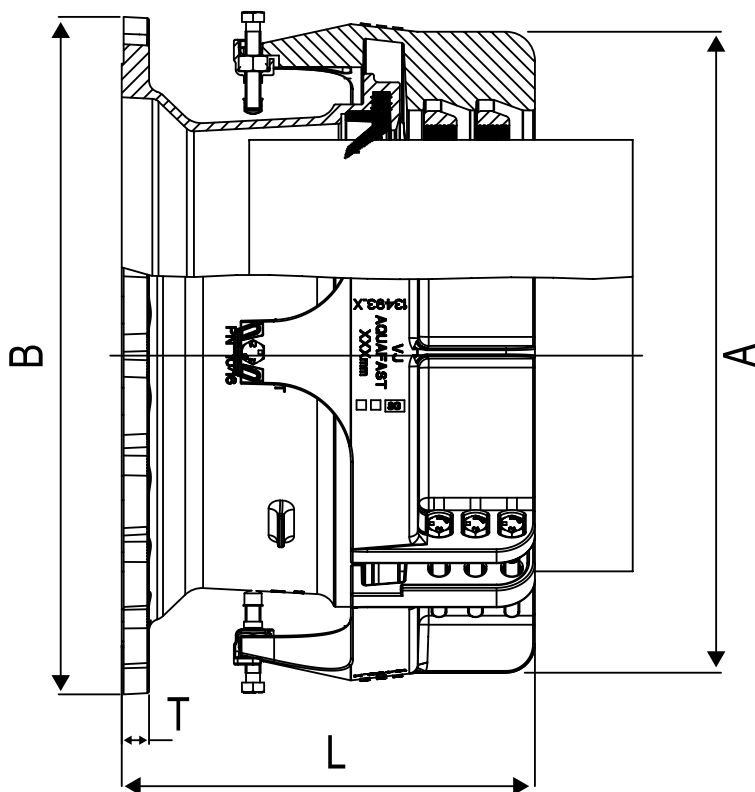

AquaFast Flange Adaptors

Nominal Size	Flange Drilling	Working Pressure (water) bar	Bolts size No dia x length	Insertion Depth (mm)			Setting gap (based on nominal insertion depth)	Outer Dimensions (mm)				Weight (kg)	
				Min	Nom	Max		Clamp Band Outer Diameter (A)		Length (L)	Flange Outer Diameter (B)		Flange Thickness (T)
								Installed	Uninstalled				
355	300 PN10,16	16	12-M16 x 120	284	304	324	197	540	571	501	455	22.5	122.2
355	350 PN10,16	16	12-M16 x 120	284	304	324	117	540	571	421	520	23.5	120.0
400	350 PN10,16	16	12-M16 x 120	289	309	329	183	585	618	492	520	23.5	134.4
400	400 PN10,16	16	12-M16 x 120	290	310	330	117	585	618	427	580	25	132.0
450	400 PN10,16	16	12-M16 x 120	298	318	338	109	635	670	427	580	25	142.9
450	450 PN10,16	16	12-M16 x 120	298	318	338	117	635	670	435	640	27	147.2
450	500 PN10,16	16	12-M16 x 120	298	318	338	117	635	670	435	715	28.5	155.4

Every effort has been made to ensure that the information contained in this publication is accurate at the time of publishing. Crane Ltd assumes no responsibility or liability for typographical errors or omissions or for any misinterpretation of the information within the publication and reserves the right to change without notice.

DR8550_03_2020_ISSUE 6

AquaFast Large Diameter Flange Adaptors 355mm to 450mm

Datasheet

2/2

Technical Information

Working Pressure Rating

Water 16 bar

Gas not approved

Vacuum Pressure

Capable of accommodating a vacuum pressure of -0.7 bar

Site Test Pressure

1.5 times working pressure for short duration (2 hours)

Pipe Material / Support Liner

When used on the following pipe materials AquaFast does not need a support liner:-

- ▶ MDPE (PE80) in SDR ratings 11 & 17/17.6
- ▶ HDPE (PE100) in SDR ratings 11, 17/17.6 & 21

Angularity (in accordance with BS EN 12842)

Flange Adaptors 1.0°

Bolt Torque/Spanner

Torque; None, simply tighten until correct installation confirmed
Correct installation confirmed through visual indication with metal to metal contact between the clamp bands.

Temperature Rating of Product

EPDM -20°C to +60°C

AquaFast is not suitable for use on heating systems with fluctuating temperatures.

End Load Due to Internal Pressure

AquaFast Fully restrained fitting, and has been designed to meet the performance requirements of BS EN 12842, WIS 4-24-01 Type 2 and ISO 17855 (supersedes ISO 14236.2).

Approvals

The following water contact materials used in AquaFast are approved for use with potable water:-

Rilsan Nylon 11:

- ▶ WRAS, AS/NZS 4020, DVGW, W270, ACS & KIWA

EPDM Gaskets:

- ▶ WRAS, AS/NZS 4020

In addition to the above, AquaFast as a finished product has KIWA certification verifying that the above products comply with the requirements of the Water Supply (Water Fittings) Regulations for England and Wales 1999, the Water Byelaws 2000, Scotland and the Water Regulations Northern Ireland.

Materials & Relevant Standards

Flange Adaptor Body, Centre Sleeve, Clamp Bands & Gripper Ring

Ductile iron to BS EN 1563 Symbol EN-GJS-450-10

Gasket

EPDM Grade 'E' to BS EN 681-1:1996 Type WA WRAS listed

Coatings

Body, Sleeve, Intermediate Ring & End Ring

- ▶ Rilsan Nylon 11 to WIS 4-52-01 Part 1

Nuts and Bolts:

- ▶ Sheraplex coated to WIS 4-52-03

Gripper:

- ▶ Cathaphoretic coating

Bolts

Standard - Stainless Steel BS EN ISO3506-1 Grade A2-70

Nuts

Standard - Stainless Steel BS EN ISO3506-2 Grade A4-80

Washers

Stainless Steel to BS1449: Part 2:1983 Grade 304S15

Every effort has been made to ensure that the information contained in this publication is accurate at the time of publishing. Crane Ltd assumes no responsibility or liability for typographical errors or omissions or for any misinterpretation of the information within the publication and reserves the right to change without notice.

DR9550_03_2020_ISSUE 6