

Simple

# Marine

Couplings & Flange Adaptors  
Approved & Pre-assembled Fittings



**VIKING JOHNSON™**

PIONEERS IN PIPE SOLUTIONS

**CRANE**

BUILDING SERVICES & UTILITIES



## Pre-assembled & Approved Fittings for Marine Applications

The proven Marine range has been designed and approved for use in marine environments. Alongside all the features and benefits of Viking Johnson's standard range, the marine fittings have attained international seals of approval from prominent marine authorities including American Bureau of Shipping (ABS) and Bureau Veritas.

### Allowing for Movement

In marine installations, pipework is often anchored to the frame of the vessel so particular care must be taken to allow for the movement of pipework as the ship travels. Marine couplings and flange adaptors aim to relieve the strain and stress that pipework may experience on board.

### Enhanced Design Features

The Marine range has enhanced design features including a galvanized finish, nitrile gasket and a locating plug which prevents coupling creep caused by repeated pipe movement. The removable locating plug ensures the coupling can slide fully over the pipe ends to ease installation and when installed, they engage between the pipe ends preventing the coupling moving beyond fixed limits.



### Typical Marine Applications

- ▶ Deck wash
- ▶ Sanitary supply
- ▶ Domestic fresh water
- ▶ Oil fuel transfer lines
- ▶ Scupper and discharge lines
- ▶ Cargo oil lines in tankers
- ▶ Hold-sounding pipes
- ▶ Inert gas
- ▶ Bilge lines
- ▶ Ballast lines
- ▶ Fuel and lubricating oil
- ▶ Filling and vent pipes
- ▶ Fresh and salt water systems

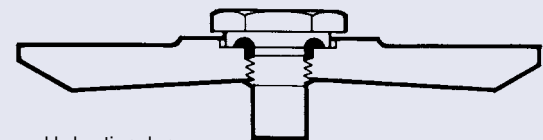

Removable locating plug.



# Marine Couplings & Flange Adaptors

## Product Design Benefits

### Corrosion Protection

Available as standard with galvanised body and bolts for the most arduous conditions.



### Fixed Fitting

Removable locating plug prevents coupling creep caused by continuous vibrations found onboard along with movement from temperature variations.



### Simple to Fit

Captive, non-rotating bolt head requires single spanner/ torque wrench to make installation simple with one bolt size (M12) across range and one bolt torque (55-65Nm) for all pipe materials.

### Reduces Noise

Resilient gasket helps absorb both noise and vibration.



## Customer Benefits

- ▶ The Marine design allows angular movement, which caters for minor misalignment and pipe deflection with couplings up to 6° and flange adaptors to 3°. Vessel movement can be accommodated without using specialised fittings.
- ▶ Marine couplings are capable of accommodating 10mm of expansion/contraction per fitting, flange adaptors 5mm which reduces the need for supplementary expansion joints or bellows.

- ▶ Marine products up to DN300 are pre-assembled allowing quick and efficient installation, without the need for dismantling, even in the most difficult of conditions.



# Marine Couplings

## Specifications

### Marine Couplings

Bolt torque 55-65Nm  
 Working Pressure As noted in table  
 (Test Pressure = 1.5 x W.P.)

Consult relevant technical literature for full details on product.

1 = Centre Sleeve  
 2 = End Ring  
 3 = Gasket  
 4 = Bolts

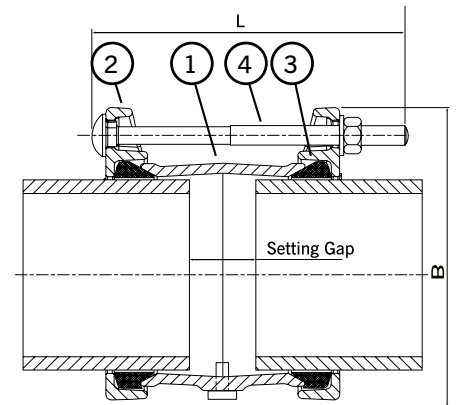

Marine Couplings DO NOT resist end load due to the internal pressure  
 - adequate external restraint must be provided to prevent pipe pull out.

Pipe OD (mm)	W.P. (bar)	No. Plugs	End Ring OD B (mm)	L (mm)	Bolt Size No.-Dia x Length	Setting gap		Gasket Mould No.	Weight (kg)
						Min	Max		
047.9 - 051.3	46.6	1 Plug	136	188	2-M12 x 180	30	40	12477/41	2.22
059.5 - 063.3	46.6	1 Plug	148	188	2-M12 x 180	30	40	12477/1	2.51
075.3 - 079.1	46.6	1 Plug	164	188	2-M12 x 180	30	40	12477/5	2.89
088.1 - 091.9	46.6	1 Plug	177	188	4-M12 x 180	30	40	12477/7	3.81
107.2 - 111.0	46.6	1 Plug	196	188	4-M12 x 180	30	40	12477/12	4.26
113.5 - 120.2	46.6	1 Plug	205	188	4-M12 x 180	30	40	12477/15	4.48
138.9 - 142.7	44.0	1 Plug	228	188	4-M12 x 180	30	40	12477/19	5.02
158.2 - 162.0	38.8	1 Plug	254	188	4-M12 x 180	30	40	12477/21	6.32
167.5 - 172.3	36.9	1 Plug	264	188	4-M12 x 180	30	40	12477/24	6.59
192.2 - 196.7	32.2	2 Plug	292	188	4-M12 x 180	30	40	12477/26	8.06
218.3 - 224.4	35.8	2 Plug	319	188	4-M12 x 180	30	40	12477/29	8.89
272.2 - 276.5	34.8	2 Plug	372	188	6-M12 x 180	30	40	12477/34	11.15
323.1 - 328.6	29.5	2 Plug	424	188	6-M12 x 180	30	40	12477/37	12.76
355.6	23.2	2 Plug	446	243	6-M12 x 235	35	50	J51LS	19.60
406.4	27.2	2 Plug	497	243	8-M12 x 235	35	50	J53LS	22.40
457.0	24.2	3 Plug	548	243	8-M12 x 235	35	50	J55LS	24.90
508.0	27.4	3 Plug	598	243	10-M12 x 235	35	50	J57LS	27.80
560.0	24.9	3 Plug	649	243	10-M12 x 235	35	50	J59LS	30.20
610.0	22.9	3 Plug	700	243	10-M12 x 235	35	50	J60LS	32.70
660.0	24.3	3 Plug	751	243	12-M12 x 235	35	50	J61LS	35.50
711.0	22.6	3 Plug	802	243	12-M12 x 235	35	50	J63LS	38.00

## Materials & Relevant Standards

### Centre Sleeve and End Rings

Ductile Iron to BS EN1563 Symbol EN-GJS-450-10  
 or Steel to BS EN10025-2 Grade S275JR

### Gaskets

EPDM to BS EN681-1, TYPE WA, WC  
 Nitrile to BS EN682 Type G  
 Other grades are available  
 - contact Viking Johnson for details

### Bolts

Steel to BS EN ISO 898-1 property class 4.8

### Nuts/Washers/Locating Plugs

Nuts - Steel to BS EN 20898-2 property class 8  
 Washer - Stainless Steel to BS1449:Part 2 GRADE 304S15  
 Locating Plugs - Steel to BS970: Part 3: Grade 230M07

### Coating

Centre sleeve / End Ring / Bolts / Nuts  
 - Galvanised  
 Locating Plug - Zn10

## Options

NBR Gasket without removable plugs  
 EPDM Gasket with removable plugs  
 EPDM Gasket without removable plugs

**Flange adaptors available on request**

Every effort has been made to ensure that the information contained in this publication is accurate at the time of publishing. Crane Ltd assumes no responsibility or liability for typographical errors or omissions or for any misinterpretation of the information within the publication and reserves the right to change without notice.

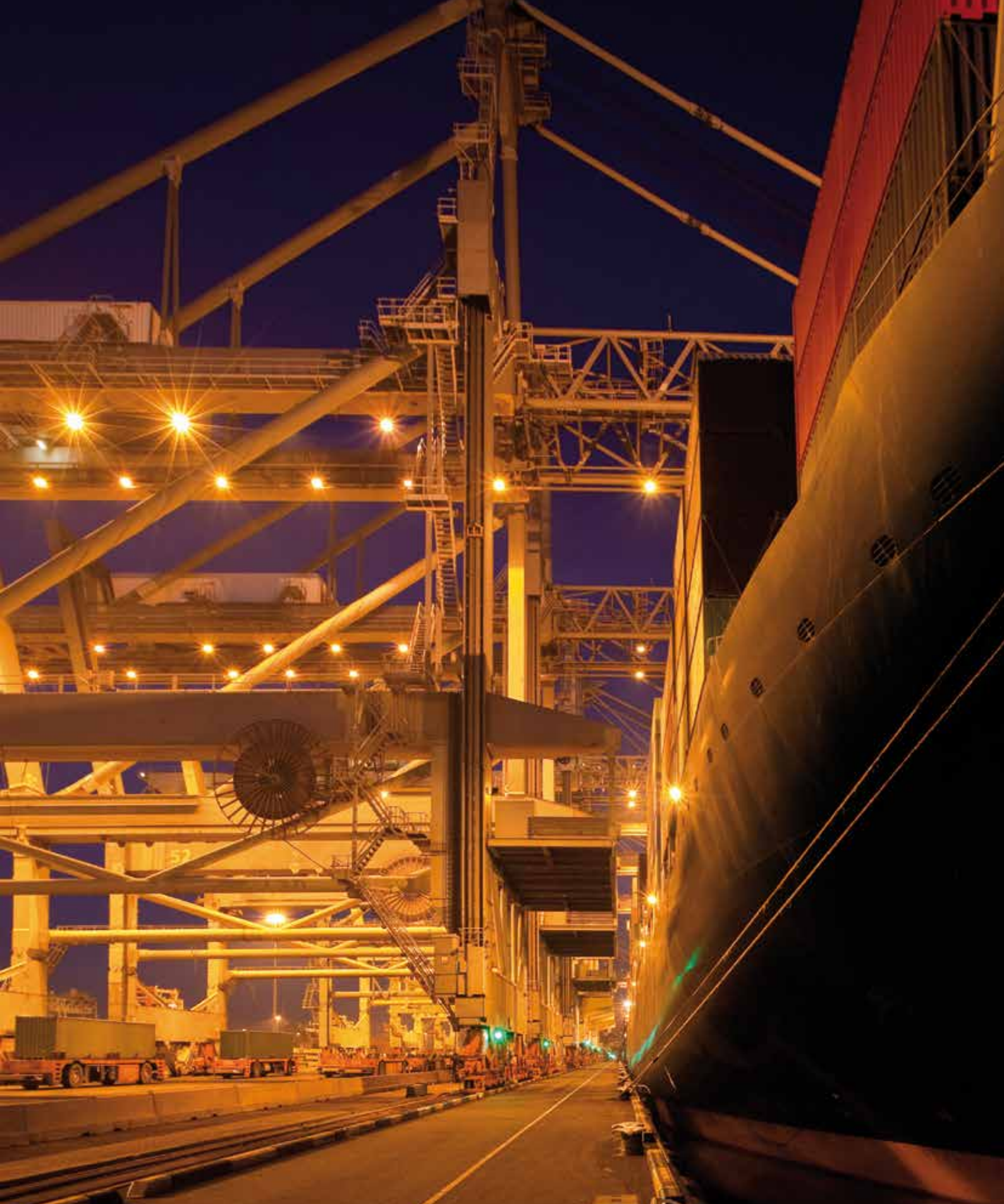

**Marine range - Internationally approved & designed  
to withstand the most arduous conditions**

United Kingdom

# 'Dunfords' Bulk Carrier

Marine Couplings

## Project

'Dunfords', a 30,000 tonne bulk carrier is equipped with marine couplings in the bilge & ballast sections of the vessel.



46-48 WILBURY WAY  
HITCHIN, HERTFORDSHIRE  
SG4 0UD. UNITED KINGDOM  
TELEPHONE: +44 (0)1462 443322  
FAX: +44 (0)1462 443311  
EMAIL: [info@vikingjohnson.com](mailto:info@vikingjohnson.com)

[www.vikingjohnson.com](http://www.vikingjohnson.com)

*Every effort has been made to ensure that the information contained in this publication is accurate at the time of publishing. Crane Ltd assumes no responsibility or liability for typographical errors or omissions or for any misinterpretation of the information within the publication and reserves the right to change without notice.*



ISO 14001 • EMS 51874



ISO 9001 • FM 00311



To visit our Video Library go to:  
[www.youtube.com/user/CraneBSU](http://www.youtube.com/user/CraneBSU)

- Designed and manufactured under quality management systems in accordance with BS EN ISO 9001.
- Environmental Management System accredited to ISO 14001.
- For full terms and conditions, please visit our website.

DF9380\_09\_2017\_GB

PIONEERS IN PIPE SOLUTIONS



[www.cranesbu.com](http://www.cranesbu.com)

