

MaxiDaptor Large Diameter Flange Adaptor PN16

Specifications

- 1 = Adaptor Body
- 2 = End Ring
- 3 = Gasket
- 4 = Stud, Nut & Washer

Working Pressure = 16bar (water)
6bar (gas)

Flange Adaptor PN16

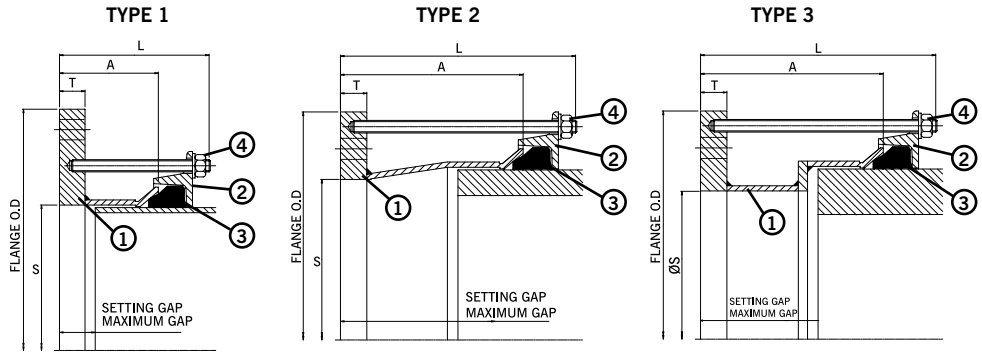

OD Range		Flange Details									Gasket Mould No.	Studs No.-Dia x Length	Setting Gap		Weight (kg)
Min (mm)	Max (mm)	Nom.	Drilling	Flange Diameter OD (mm)	Flange Bore S (mm)	Flange Thickness T (mm)	Type	Sleeve Length A (mm)	Overall Length L (mm)	Min (mm)			Max (mm)		
348.5	365.5	350	PN16	520.0	367.5	18	2	120	218	6008	8-M12 x 205	45	68	28.5	
351.0	368.0	300	PN16	478.0	300.0	18	3	240	333	6002	6-M12 x 325	165	188	38.5	
351.0	368.0	300	PN16	478.0	329.0	18	3	240	333	6002	6-M12 x 325	165	188	36.5	
351.0	368.0	350	PN16	520.0	370.0	18	1	120	218	6002	8-M12 x 205	45	68	28.6	
374.5	391.5	300	PN16	502.0	300.0	18	3	240	333	1659	6-M12 x 325	160	183	43.1	
374.5	391.5	350	PN16	520.0	350.0	18	1	120	218	1659	8-M12 x 205	45	68	31.0	
374.5	391.5	350	PN16	520.0	393.5	18	1	120	218	1659	8-M12 x 205	45	68	27.5	
374.5	391.5	400	PN16	580.0	393.5	25	1	120	218	1659	8-M12 x 205	45	68	41.6	
394.3	411.3	350	PN16	522.0	350.0	18	2	205	298	1766	8-M12 x 290	130	153	37.1	
394.3	411.3	350	PN16	520.0	397.5	18	2	205	303	1766	8-M12 x 290	130	153	33.1	
394.3	411.3	400	PN16	580.0	413.5	25	1	120	220	1766	8-M12 x 205	45	68	39.8	
404.8	421.8	400	PN16	580.0	400.0	18	1	120	213	1767	8-M12 x 205	45	68	34.9	
404.8	421.8	400	PN16	580.0	424.0	18	1	120	218	1767	8-M12 x 205	45	68	32.8	
418.2	435.2	400	PN16	580.0	437.0	18	1	120	218	1784	8-M12 x 205	45	68	32.0	
425.0	442.0	400	PN16	580.0	400.0	18	1	120	218	1662	8-M12 x 205	45	68	35.7	
425.0	442.0	400	PN16	580.0	444.0	18	1	120	218	1662	8-M12 x 205	45	68	31.6	
434.4	451.4	400	PN16	580.0	448.0	18	2	205	303	1768	8-M12 x 290	130	153	37.4	
447.2	464.2	400	PN16	580.0	400.0	18	2	205	303	1769	8-M12 x 290	130	153	42.2	
447.2	464.2	400	PN16	580.0	448.0	18	2	205	303	1769	8-M12 x 290	130	153	37.7	
455.0	472.0	400	PN16	582.0	400.0	18	2	205	298	6003	8-M12 x 290	130	153	42.6	
455.0	472.0	450	PN16	640.0	450.0	23	1	120	218	6003	10-M12 x 205	45	68	46.0	
455.0	472.0	450	PN16	640.0	474.0	23	1	120	218	6003	10-M12 x 205	45	68	42.8	
462.5	479.5	400	PN16	590.0	440.0	25	2	205	303	10511/40	8-M12 x 290	130	153	45.7	
467.0	484.0	450	PN16	640.0	486.0	23	1	120	218	6073	10-M12 x 205	45	68	41.6	
476.0	493.0	400	PN16	603.0	400.0	23	3	255	338	1770	8-M12 x 325	180	203	60.8	
476.0	493.0	450	PN16	640.0	495.0	23	1	120	218	1770	10-M12 x 205	45	68	40.7	
487.3	504.3	450	PN16	640.0	506.5	23	1	120	218	1771	10-M12 x 205	45	68	39.4	
487.3	504.3	500	PN16	715.0	506.5	23	1	120	218	1771	10-M12 x 205	45	68	53.2	
501.9	518.9	450	PN16	640.0	485.5	23	2	205	303	1772	10-M12 x 290	130	153	48.7	
501.9	518.9	500	PN16	715.0	500.0	23	1	120	218	1772	10-M12 x 205	45	68	54.7	
501.9	518.9	500	PN16	715.0	521.0	23	1	120	218	1772	10-M12 x 205	45	68	51.7	
510.0	527.0	450	PN16	640.0	494.0	23	2	205	303	6004	10-M12 x 290	130	153	47.9	
510.0	527.0	500	PN16	715.0	500.0	23	1	120	218	6004	10-M12 x 205	45	68	54.9	
527.0	544.0	500	PN16	715.0	500.0	23	1	120	218	1773	10-M12 x 205	45	68	55.6	
527.0	544.0	500	PN16	715.0	546.0	23	1	120	218	1773	10-M12 x 205	45	68	48.8	
540.1	557.1	500	PN16	715.0	559.0	23	1	120	218	1774	10-M12 x 205	45	68	47.2	
555.3	572.3	500	PN16	715.0	550.0	23	2	205	303	1775	10-M12 x 290	130	153	56.0	
555.3	572.3	600	PN16	840.0	649.5	25	1	120	218	1775	10-M12 x 205	45	68	62.3	

Materials & Relevant Standards

Flange Adaptor Body

Mild Steel to BS EN 10025-2 Grade S275

End Ring

Rolled Steel to BS EN 10025-2 Grade S275

Gasket

EPDM Grade "E" to BS EN 681-1 Type WA WRAS Listed

Bolt Torque / Spanner

Bolt torque - 55-65Nm / Spanner size - A/F 19mm

Coating

Flange Adaptor Body & End Ring = Rilsan Nylon 11 to WIS 4-52-01 Part 1

Bolts & Nuts = Sheraplex to WIS 4-52-03

Studs, Nuts & Washer

Studs

Standard - Steel to BS EN ISO 898-1 Property Class 4.8

Option - Stainless Steel to BS EN ISO 3506-1: grade A4 property class 50

Nuts

Standard - Steel to BS EN 4190 Grade 4

Option - Stainless Steel to BS EN ISO 3506-2: grade A4 property class 80

Washers

Stainless Steel to BS 1449:Part 2 Grade 304 S15

Every effort has been made to ensure that the information contained in this publication is accurate at the time of publishing. Crane Ltd assumes no responsibility or liability for typographical errors or omissions or for any misinterpretation of the information within the publication and reserves the right to change without notice.

MaxiDaptor Large Diameter Flange Adaptor PN16

Specifications

- 1 = Adaptor Body
- 2 = End Ring
- 3 = Gasket
- 4 = Stud, Nut & Washer

Working Pressure = 16bar (water)
6bar (gas)

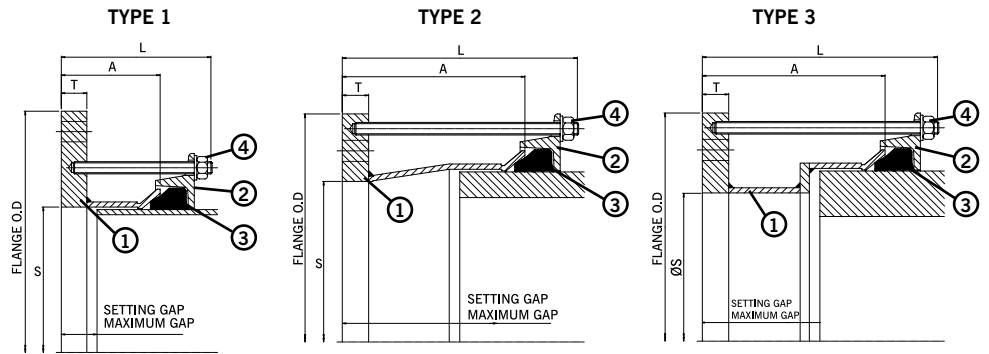

Flange Adaptor PN16 Continued

OD Range		Flange Details								Gasket Mould No.	Studs No.-Dia x Length	Setting Gap		Weight (kg)
Min (mm)	Max (mm)	Nom.	Drilling	Flange Diameter OD (mm)	Flange Bore S (mm)	Flange Thickness T (mm)	Type	Sleeve Length A (mm)	Overall Length L (mm)			Min (mm)	Max (mm)	
566.5	583.5	500	PN16	715.0	500.0	23	2	205	303	1776	10-M12 x 290	130	153	63.6
566.5	583.5	500	PN16	715.0	550.0	23	2	205	303	1776	10-M12 x 290	130	153	56.2
582.2	599.2	500	PN16	715.0	560.0	23	3	205	303	1777	10-M12 x 290	130	153	60.4
582.2	599.2	600	PN16	840.0	601.0	25	1	120	218	1777	10-M12 x 205	45	68	72.5
601.0	618.0	600	PN16	840.0	600.0	25	1	120	218	6020	10-M12 x 205	45	68	73.4
601.0	618.0	600	PN16	840.0	620.0	25	1	120	218	6020	10-M12 x 205	45	68	69.7
613.0	630.0	600	PN16	840.0	632.0	23	1	120	218	6019	10-M12 x 205	45	68	64.4
618.0	635.0	600	PN16	840.0	637.0	23	1	120	218	6025	10-M12 x 205	45	68	63.6
630.5	647.5	600	PN16	840.0	600.0	23	1	120	218	1778	10-M12 x 205	45	68	70.6
630.5	647.5	600	PN16	840.0	649.5	23	1	120	218	1778	10-M12 x 205	45	68	61.8
645.2	662.2	600	PN16	840.0	664.0	23	1	120	218	1779	10-M12 x 205	45	68	59.7
662.0	679.0	600	PN16	840.0	681.0	23	1	120	218	1780	10-M12 x 205	45	68	57.1
675.0	692.0	600	PN16	840.0	653.0	23	2	205	303	6005	10-M12 x 290	130	153	70.6

Materials & Relevant Standards

Flange Adaptor Body

Mild Steel to BS EN 10025-2 Grade S275

End Ring

Rolled Steel to BS EN 10025-2 Grade S275

Gasket

EPDM Grade "E" to BS EN 681-1 Type WA WRAS Listed

Bolt Torque / Spanner

Bolt torque - 55-65Nm / Spanner size - A/F 19mm

Coating

Flange Adaptor Body & End Ring = Rilsan Nylon 11 to WIS 4-52-01 Part 1

Bolts & Nuts = Sheraplex to WIS 4-52-03

Studs, Nuts & Washer

Studs

Standard - Steel to BS EN ISO 898-1 Property Class 4.8

Option - Stainless Steel to BS EN ISO 3506-1: grade A4 property class 50

Nuts

Standard - Steel to BS EN 4190 Grade 4

Option - Stainless Steel to BS EN ISO 3506-2: grade A4 property class 80

Washers

Stainless Steel to BS 1449:Part 2 Grade 304 S15