

LinerGrip Standard Range 50mm to 1000mm

Specifications

LinerGrip Cross Section

- | | |
|--------------------|---------------------|
| 1) Host End Ring | 5) Gasket Divider |
| 2) Host Gasket | 6) LinerGrip Gasket |
| 3) Main Body | 7) Main Flange Body |
| 4) Gripper Segment | 8) Coated Insert |
- A) Host Pipe
B) Polyethylene Liner Pipe

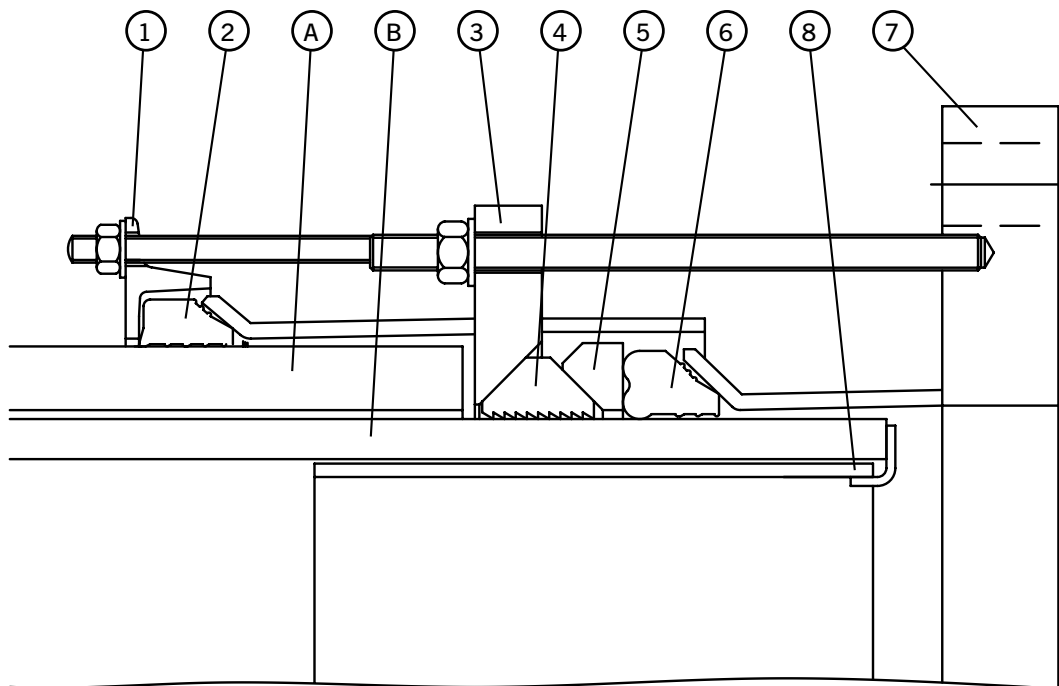

Materials and Relevant Standards

Centre Sleeve/End Rings/Flange Adaptor Body

Rolled Steel to BS EN 10025 Grade S275JR or Equivalent

Gripper Links

Acetal Copolymer Grade M90 or equivalent

Bolts/Studs/Nuts/Washers

Bolts and Studs - Steel to BS EN ISO 898-1 Property Class 4.8

Nuts - Mild Steel to BS 4190 Grade 4

Washers - Stainless Steel to BS1449:Part 2: Grade 304S15

Gasket

Compound to suit application. Contact Viking Johnson for advice

Coating

Body, Sleeve and End Rings - Coated in Rilsan Nylon 11 to WIS 4-52-01 (Part 1)

Bolts and Nuts - Sheraplex to WIS 4-52-03

Every effort has been made to ensure that the information contained in this publication is accurate at the time of publishing. Crane Ltd assumes no responsibility or liability for typographical errors or omissions or for any misinterpretation of the information within the publication and reserves the right to change without notice.