

Large Diameter Stepped Couplings OD355.6 - 1222

Specifications

L = Distance back from end of pipe that must be rounded, meet tolerances, and free from any wrapping to ensure correct assembly.

Coupling Type	Coupling Section Type	Sleeve Length S (mm)	Dimensions (mm)		Setting Gap X (mm)		Bolt Details		
			Distance L	Overall C	Min.	Max.	Bolt Dia.	Length (mm)	Torque (Nm)
Standard Sleeve	L02	150	150	243	25	50	M12	235	55 - 65
Long Sleeve	L03	250	200	348	25	150	M12	340	55 - 65
Standard Sleeve	YF2	178	150	276	38	76	M16	265	95 - 120
Long Sleeve	YF3	250	200	351	38	150	M16	340	95 - 120
Standard Sleeve	A2E	178	150	276	38	76	M16	265	95 - 120
Long Sleeve	A2H	254	200	351	38	150	M16	340	95 - 120
Standard Sleeve	XSXG	254	200	411	57	117	M16	400	95 - 120

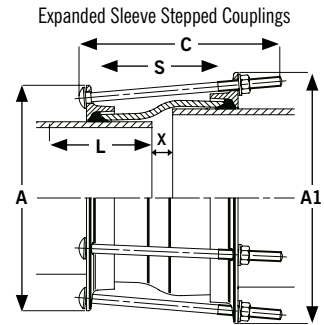

NOTES
General Viking Johnson manufacture stepped couplings to any pipe OD and pressure. If the product required is not shown in any of our tables please contact Viking Johnson who can provide the relevant information.
Pressure Working pressure is as shown in the table. Site test pressure is 1.5x working pressure.
End Restraint Dedicated stepped couplings DO NOT resist end load due to the internal pressure - adequate external restraint must be provided to prevent both pipe pull out from the stepped coupling and also coupling moving along the smaller diameter pipe.

Pipe OD (mm)		Pipe Material End 1		Tolerance on Pipe OD for Distance L		Pipe Material End 2		Tolerance on Pipe OD for Distance L		Working Pressure (bar)	Gasket Mould No.		Coupling Section Type		Bolts No. x Dia	Weight (kg)		Dimensions (mm)		Bolt Length		Dimensions Overall C	
				(mm) +	(mm) -						End 1	End 2	Standard Sleeve	Long Sleeve		Standard Sleeve	Long Sleeve	Diameter A End 1	Diameter A1 End 2	Standard Sleeve	Long Sleeve	Standard Sleeve	Long Sleeve
355.6	378	Steel & uPVC	1.6	1.6	Ductile Iron	2.7	3.5	29.2	J51LS	J52LS	L02	L03	8 x M12	20.7	27.8	446	469	235	340	243	348		
358.6	378	Coated Steel	1.6	1.6	Ductile Iron	2.7	3.5	29.2	J51LS	J52LS	L02	L03	8 x M12	20.7	27.8	450	469	235	340	243	348		
406.4	429	Steel & uPVC	1.6	1.6	Ductile Iron	2.8	4.0	25.7	J53LS	J54LS	L02	L03	8 x M12	23.1	31.1	497	520	235	340	243	348		
409.6	429	Coated Steel	1.6	1.6	Ductile Iron	2.8	4.0	25.7	J53LS	J54LS	L02	L03	8 x M12	23.2	31.2	499	520	235	340	243	348		
457	480	Steel & uPVC	1.6	1.6	Ductile Iron	2.9	4.0	23.1	J55LS	J56LS	L02	L03	8 x M12	25.6	34.5	548	571	235	340	243	348		
460	480	Coated Steel	1.6	1.6	Ductile Iron	2.9	4.0	23.1	J55LS	J56LS	L02	L03	8 x M12	25.7	34.5	551	571	235	340	243	348		
480	508	Ductile Iron	2.9	4.0	Steel & uPVC	1.6	1.6	27.3	J56LS	J57LS	L02	L03	10 x M12	27.3	36.7	571	598	235	340	243	348		
480	511	Ductile Iron	2.9	4.0	Coated Steel	1.6	1.6	27.2	J56LS	J57LS	L02	L03	10 x M12	27.5	36.9	571	602	235	340	243	348		
508	532	Steel & uPVC	1.6	1.6	Ductile Iron	3.0	4.0	26.1	J57LS	J58LS	L02	L03	10 x M12	28.6	38.4	598	624	235	340	243	348		
511	532	Coated Steel	1.6	1.6	Ductile Iron	3.0	4.0	26.1	J57LS	J58LS	L02	L03	10 x M12	28.6	38.5	602	624	235	340	243	348		
610	635	Steel & uPVC	1.6	1.6	Ductile Iron	3.2	4.5	22.0	J60LS	J61LS	L02	L03	10 x M12	33.6	45.2	700	726	235	340	243	348		
613	635	Coated Steel	1.6	1.6	Ductile Iron	3.2	4.5	22.0	J60LS	J61LS	L02	L03	10 x M12	33.6	45.2	703	726	235	340	243	348		
711	738	Steel	1.6	1.6	Ductile Iron	3.4	4.5	21.7	J63LS	J63LS	L02	L03	12 x M12	39.0	52.5	802	830	235	340	243	348		
714	738	Coated Steel	1.6	1.6	Ductile Iron	3.4	4.5	21.7	J63LS	J63LS	L02	L03	12 x M12	39.0	52.5	805	830	235	340	243	348		
738	747	Ductile Iron	3.4	4.5	Cast Iron CD	3.3	3.3	21.3	J63LS	J63LS	L02	L03	12 x M12	39.4	53.2	830	839	235	340	243	348		
738	755	Ductile Iron	3.4	4.5	Cast Iron AB	3.3	3.3	21.2	J63LS	J65LS	L02	L03	12 x M12	39.9	53.7	830	847	235	340	243	348		
813	842	Steel	1.6	1.6	Ductile Iron	1.0	4.5	18.8	J65LS	J65LS	L02	L03	14 x M12	44.4	59.7	903	931	235	340	243	348		
816	842	Coated Steel	1.6	1.6	Ductile Iron	1.0	4.5	18.8	J65LS	J65LS	L02	L03	14 x M12	44.4	59.8	906	931	235	340	243	348		
826	842	Cast Iron CD	3.3	3.3	Ductile Iron	1.0	4.5	18.8	J65LS	J65LS	L02	L03	14 x M12	44.3	59.8	918	931	235	340	243	348		
842	886	Ductile Iron	1.0	4.5	Cast Iron AB	3.3	3.3	17.0	J65LS	J65LS	-	L03	14 x M12	-	62.7	931	978	-	340	-	348		
906	945	Cast Iron CD	3.3	3.3	Ductile Iron	1.0	5.0	22.0	J67LS	J70LS	YF2	YF3	12 x M16	86.5	102.6	1017	1054	265	340	276	351		
914	945	Steel	1.6	1.6	Ductile Iron	1.0	5.0	22.0	J67LS	J70LS	YF2	YF3	12 x M16	86.5	102.7	1005	1054	265	340	276	351		
916	945	Coated Steel	1.6	1.6	Ductile Iron	1.0	5.0	22.0	J67LS	J70LS	YF2	YF3	12 x M16	86.5	102.7	1007	1054	265	340	276	351		
945	964	Ductile Iron	1.0	5.0	Cast Iron AB	3.3	3.3	21.6	J70LS	J70LS	YF2	YF3	12 x M16	88.3	104.9	1054	1075	265	340	276	351		
1016	1048	Steel	1.6	1.6	Ductile Iron	1.0	5.0	18.3	J71LS	J71LS	YF2	YF3	14 x M16	95.9	114.1	1125	1156	265	340	276	351		
1019	1048	Coated Steel	1.6	1.6	Ductile Iron	1.0	5.0	18.3	J71LS	J71LS	YF2	YF3	14 x M16	95.9	114.2	1129	1156	265	340	276	351		
1121	1152	Cast Iron AB	3.3	3.3	Ductile Iron	1.0	6.0	24.3	J120M	J121M	A2E	A2H	16 x M16	137.6	164.9	1247	1275	265	340	276	351		
1219	1255	Steel	1.6	1.6	Ductile Iron	1.0	6.0	25.2	J120M	J132M	A2E	A2H	18 x M16	150.1	179.8	1344	1379	265	340	276	351		
1222	1255	Coated Steel	1.6	1.6	Ductile Iron	1.0	6.0	25.2	J120M	J132M	A2E	A2H	18 x M16	150.1	179.8	1347	1379	265	340	276	351		

Materials & Relevant Standards

Centre Sleeve/End Rings

Steel to BS EN10025-2:2004 Grade S275JR

Bolts/Nuts/Washers

Bolts - Steel to BS EN ISO898-1:2009

Property Class 4.8

Nuts - Steel to BS4190:2001 Grade 4

Washers - Stainless Steel to BS1449:Part 2:1983

Grade 304S15

Every effort has been made to ensure that the information contained in this publication is accurate at the time of publishing. Crane Ltd assumes no responsibility or liability for typographical errors or omissions or for any misinterpretation of the information within the publication and reserves the right to change without notice.

Coatings

Body, Flange & End Ring - Rilsan Nylon 11 to WIS 4-52-01 Part 1

Nuts and Bolts - Sheraplex coated to WIS 4-52-03

Gaskets: L02/L03/YF2/YF3

Rubber 80 IRHD Moulded Compound to BS

EN681-1:1996 Type WA,WC,WG or BS

EN682:2002, Type G (other materials available on request)

Gaskets: A2E/A2H/XSXG

Rubber 70 IRHD Moulded Compound to BS

EN681-1:1996 Type WA, WC, WG or BS

EN682:2002, Type G

(other materials available on request)