

Dismantling Joint DN350 to DN2400 (PN10)

Specifications

Note: Maximum Longitudinal Adjustment
= Maximum Length – Minimum Length

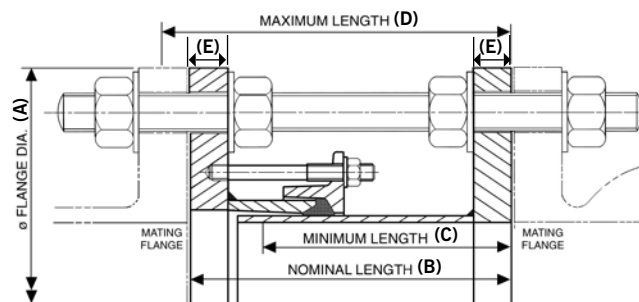

Dismantling Joint

Flange Details				Flange To Flange Details			Tie Rod Details					
Nom	Drilling	Flange Thickness	Flange OD	Nominal Length	Minimum Length	Maximum Length	Steel Tie Rod			Stainless Steel Tie Rod		
		E (mm)	A (mm)	B (mm)	C (mm)	D (mm)	Dia x Length (mm)	No.	Total Weight of DJ (kg)	Dia x Length (mm)	No.	Total Weight of DJ (kg)
350	PN10	18	505	295	270	320	M20 x 430	4	57.7	M20 x 430	4	57.7
400	PN10	18	565	295	270	320	M24 x 440	4	68.9	M24 x 440	4	68.9
450	PN10	23	615	300	275	325	M24 x 450	5	87.2	M24 x 450	5	87.2
500	PN10	23	670	300	275	325	M24 x 460	5	97.1	M24 x 460	5	97.1
550	PN10	23	730	300	275	325	M27 x 470	5	112.0	M27 x 470	5	112.0
600	PN10	23	780	300	275	325	M27 x 470	5	120.0	M27 x 470	5	120.0
650	PN10	23	835	300	275	325	M27 x 480	6	132.0	M27 x 480	6	132.0
700	PN10	23	895	300	275	325	M27 x 480	6	146.0	M27 x 480	6	146.0
800	PN10	23	1015	300	275	325	M30 x 500	6	167.0	M30 x 500	8	169.0
900	PN10	25	1115	307	277	337	M30 x 520	7	211.0	M30 x 520	8	215.6
1000	PN10	25	1230	307	277	337	M33 x 530	7	246.0	M33 x 530	8	251.0
1100	PN10	25	1340	307	277	337	M33 x 540	8	276.0	M33 x 540	10	286.0
1200	PN10	38	1455	320	290	350	M36 x 570	8	414.0	M36 x 570	10	426.0
1300	PN10	38	1575	320	290	350	M39 x 590	8	475.0	M39 x 590	10	491.0
1400	PN10	38	1675	320	290	350	M39 x 600	9	509.0	M39 x 600	12	533.0
1500	PN10	38	1785	320	290	350	M39 x 610	9	606.0	M39 x 610	12	631.0
1600	PN10	38	1915	320	290	350	M45 x 630	10	731.0	M45 x 630	10	731.0
1800	PN10	38	2115	320	290	350	M45 x 650	11	829.0	M45 x 650	14	866.0
2000	PN10	60	2325	462	412	512	M45 x 830	12	1,412.0	M45 x 830	16	1,470.0
2200	PN10	60	2550	462	412	512	M52 x 860	13	1,699.0	M52 x 950	14	1,775.0
2400	PN10	60	2760	462	412	512	M52 x 880	14	1,878.0	M52 x 970	18	2,032.0

Materials & Relevant Standards

Flange Drilling

BS EN1092-1 (formerly BS4504), ISO7005

Fabricated Flange Adaptor

Body - Rolled Steel to BS EN 10025-2: Grade S275

End Rings/Sleeve - Rolled Steel to BS EN 10025-2: Grade S275 or Rolled Steel to BS EN 10025-2: Grade S355 (depending on section)

Flanged Spigot

Flange - Rolled Steel to BS EN 10025-2: Grade S275

Spigot - Steel Tube to BS10216-1: Grade P265TR1 or Rolled Steel to BS EN 10025-2: Grade S275

Gaskets

BS EN681-1: Type WA WRAS listed

Steel Tie Rods & Nuts

Tie Rods - BS EN10269: Name 42CrMo4 (Yield 725N/mm²) (formerly MB7)

Nuts - BS EN20898-2: Property Class 8.0

Stainless Steel Tie Rods & Nuts

Tie Rods - Stainless Steel to BS EN3506-1: Grade A2/A4 Property Class 70 (Yield 450N/mm²)

Nuts (sizes up to & including M48) 4 per Tie Rod - Stainless Steel to BS EN3506-2: Grade A2/A4 Property Class 80

Nuts (sizes over M48) 6 per Tie Rod - Stainless Steel to BS EN3506-2: Grade A2/A4 Property Class 50

Studs/Nuts/Washers

Studs - Steel to BS EN ISO898-1: Property Class 4.8

Nuts - Steel to BS4190: Grade 4

Washers - Stainless Steel to BS1449:Part 2: Grade 304S15

Coatings (Others available on request)

Fabricated Flange Adaptor - Rilsan Nylon 11

Flanged Spigot - Rilsan Nylon 11

End Ring - Rilsan Nylon 11

Studs/Nuts - Sheraplex to WIS 4-52-03

Steel Tie Rods/Nuts - Zn3 Zinc coated

Every effort has been made to ensure that the information contained in this publication is accurate at the time of publishing. Crane Ltd assumes no responsibility or liability for typographical errors or omissions or for any misinterpretation of the information within the publication and reserves the right to change without notice.