

# FlexLock



## Couplings & Flange Adaptors

INSTALLATION INSTRUCTIONS – GB



PIPE CONNECTIONS • REPAIR • FLOW CONTROL PRODUCTS



# FlexLock Coupling

These fitting instructions apply to Viking Johnson FlexLock Couplings; i.e. the coupling components, centre sleeve, end rings, gaskets, bolts nuts and washers are supplied unassembled.

## For steel and iron ductile iron pipe

1. Check that the pipe end is round, smooth, free from bulges, dents, loose surface deposits and score marks. For steel pipe ensure that weld beads are ground flush to correct surface profile. When used on coated steel pipe the maximum permitted coating thickness is 500 microns.

Ensure the pipe OD is in accordance with:

**Steel Pipe:** BS534: 1990 as defined for slip on couplings

**Ductile Iron Pipe:** BS EN 545 spigot end

2. Align pipe to be laid with pipe already in position. Check pipes are concentric, adjusting supports or bed of trench if required.
3. Place end rings over pipe ends as shown. To aid installation, mark pipes half the sleeve width plus an end ring back from the pipe ends. Lubricate gasket with pipe jointing lubricant and stretch onto pipe ends with the thicker end towards the end ring.
4. Place sleeve onto pipe already in position. Adjust setting gap as required – 20mm is recommended for general usage. **(If pipe ends are axially fixed, or butt together locking may occur before sealing. Ensure pipe can move together during bolt-up).** If in doubt check with Viking Johnson Marketing Department. Centralise sleeve over pipe ends.
5. Push gaskets forward onto gasket chambers of centre sleeve, easing forward if teeth catch on pipe surface.
6. Push end rings forward into position and line up boltholes. Fit all bolts from the same side ensuring that D-necks locate in holes. Fit nuts and finger tighten.

Fig. 1

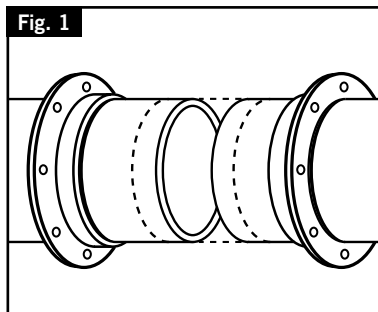

Fig. 2

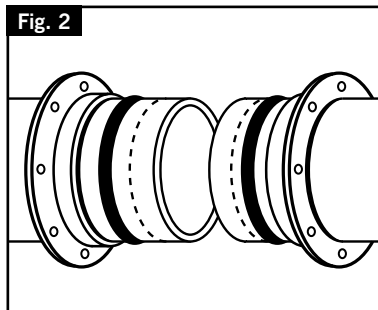

Fig. 3

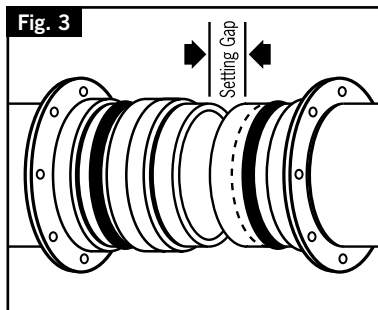
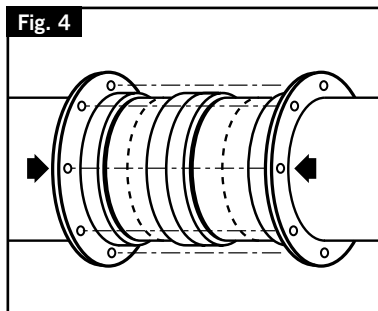

Fig. 4



7. Check coupling is central using marks made at stage 3. Tighten diametrically opposed bolts, giving the nuts one or two turns at a time to draw the end rings up evenly, working around the coupling as many times as necessary to achieve the required torque.

**Important:** Bolt torque on ALL bolts must be achieved. See below for level.

8. On completion, radial gap between pipe and coupling end rings should be even all round. Rubber may be seen to extrude into the gap.

**Bolt Torque Table**

Bolt	Torque	
	lbf.ft	Nm
M12	40 - 50	55 - 65
M16	70 - 90	95 - 120

**Notes:**

A) Maximum operating temperature for Flexlock is 40°C

B) Working Pressure

**50-200mm**

Maximum Working Pressure – 16 bar

Maximum Test Pressure – 24 bar

**250-300mm**

Maximum Working Pressure – 10 bar

Maximum Test Pressure – 15 bar

C) Setting gap - min / recommended 20mm Max 40mm.

**THE FLEXLOCK GASKET IS NOT SUITABLE FOR APPLICATIONS IN EXCESS OF THESE PRESSURES. GASKET SHOULD NOT BE RE-USED.**

Use of a Flexlock product on a pipe produces indentation in the pipe surface at each tooth location. If a Flexlock product is used on a pipe that has these indentations, the following instructions must be followed.

- i) Metal build up left by the effect of the gripping teeth **MUST** be removed.
- ii) The gripping teeth of the new gasket **MUST NOT** coincide with the indentations left by the previous gasket. See Figure 6.

Failure to observe the above note could result in the Flexlock product being unable to retain its End Load capabilities up to its full rated working pressure.

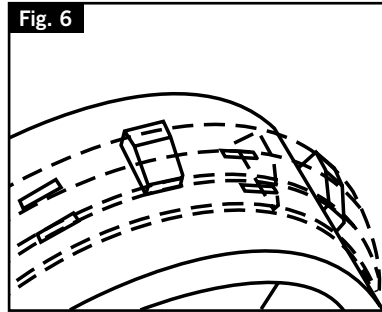
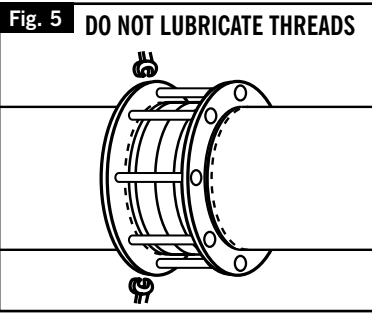



# FlexLock Flange Adaptor

These fitting instructions apply to Viking Johnson FlexLock Flange Adaptors; i.e. the coupling components, centre sleeve, end rings, gaskets, bolts nuts and washers are supplied unassembled.

## For steel and iron ductile iron pipe

1. Check that the pipe end is round, smooth, free from bulges, dents, loose surface deposits and score marks. For steel pipe ensure that weld beads are ground flush to correct surface profile. When used on coated steel pipe the maximum permitted coating thickness is 500 microns.

Ensure the pipe OD is in accordance with:

**Steel Pipe:** BS534: 1990 as defined for slip on couplings

**Ductile Iron Pipe:** BS EN 545 spigot end

2. Dismantle adaptor by removing end ring from studs, retaining the nuts. Place end ring onto pipe end with the gasket chamber facing the mating flange. Lubricate gasket with pipe jointing lubricant and stretch onto pipe end with the thicker end towards the end ring.
3. Place adaptor body onto pipe. Adjust setting gap as required – 10mm is recommended for general usage. **(If pipe is axially fitted or butts with fixed flange, etc, locking may occur before sealing. Ensure pipe can move axially during bolt-up).**

If in doubt check with Viking Johnson Marketing Department.

4. Fit mating flange gasket. Ensure that all components remain concentric during bolt-up.
5. Bolt adaptor body to mating flange using standard flange bolting procedures.
6. Push gasket forward into gasket chamber of adaptor body, easing forward if teeth catch on pipe surface.

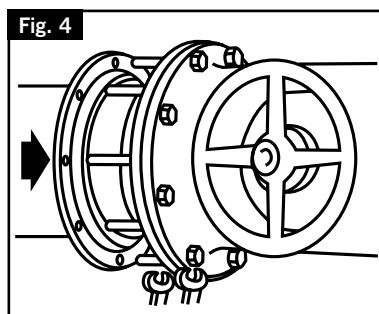
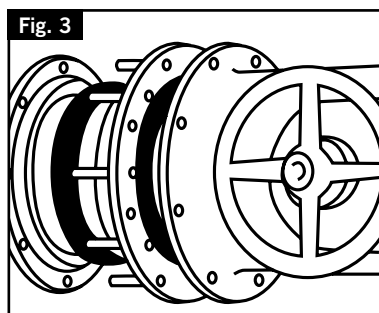
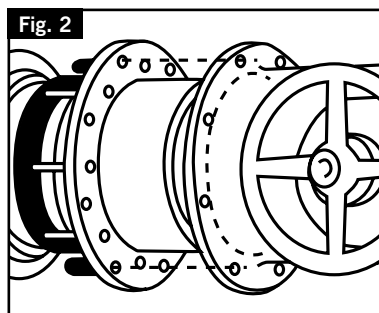
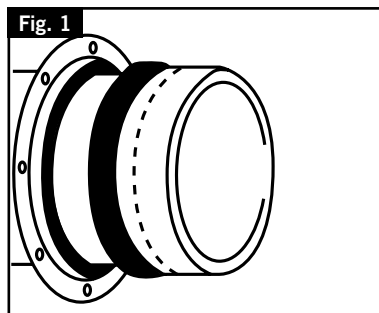

7. Push end ring forward into position locating D holes over studs. Fit nuts and tighten diametrically opposed bolts, giving the nuts one or two turns at a time to draw the end ring up evenly, working around the adaptor as many times as necessary to achieve the required torque.

**Important:** Bolt torque on ALL bolts must be achieved. See below for level.

8. On completion, radial gap between pipe and adaptor end ring should be even all round. Rubber may be seen to extrude the gap.

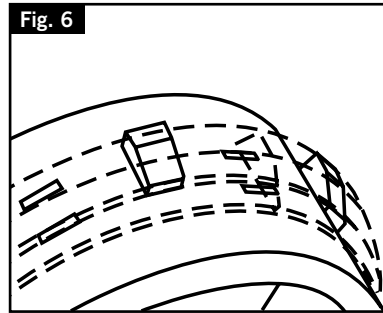
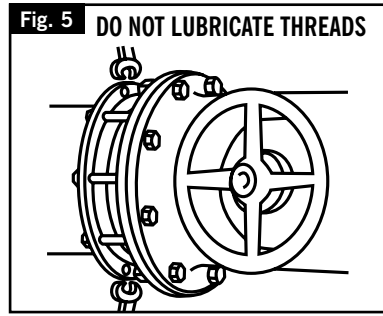

Bolt Torque Table		
Bolt	Torque	
	lbf.ft	Nm
M12	40 - 50	55 - 65
M16	70 - 90	95 - 120

A) Maximum operating temperature is 40°C

B) Working Pressure

**50-200mm**

Maximum Working Pressure – 16 bar

Maximum Test Pressure – 24 bar

**250-300mm**

Maximum Working Pressure – 10 bar

Maximum Test Pressure – 15 bar

PN16 drillings are available in 250 & 300 sizes but product has a maximum working pressure of 10bar

C) Setting gap - min / recommended 10mm Max 30mm.

**THE FLEXLOCK GASKET IS NOT SUITABLE FOR APPLICATIONS IN EXCESS OF THESE PRESSURES. GASKET SHOULD NOT BE RE-USED.**

Use of a Flexlock product on a pipe produces indentation in the pipe surface at each tooth location. If a Flexlock product is used on a pipe that has these indentations, the following instructions must be followed.

- i) Metal build up left by the effect of the gripping teeth **MUST** be removed.
- ii) The gripping teeth of the new gasket **MUST NOT** coincide with the indentations left by the previous gasket. See Figure 6.

Failure to observe the above note could result in the Flexlock product being unable to retain its End Load capabilities up to its full rated working pressure.







ISO 14001 • EMS 51874



ISO 9001 • FM 00311



To visit our Video Library go to:  
<http://www.youtube.com/user/CraneBSU>

DR7373\_04\_2014



46-48 WILBURY WAY  
HITCHIN,  
HERTFORDSHIRE  
SG4 0UD. UK

TELEPHONE: +44 (0)1462 443322  
FAX: +44 (0)1462 443311  
EMAIL: [info@vikingjohnson.com](mailto:info@vikingjohnson.com)  
[www.vikingjohnson.com](http://www.vikingjohnson.com)

Every effort has been made to ensure that the information contained in this publication is accurate at the time of publishing. Crane Ltd assumes no responsibility or liability for typographical errors or omissions or for any misinterpretation of the information within the publication and reserves the right to change without notice.