

MaxiDaptor Large Diameter Flange Adaptor PN10

Specifications

- 1 = Make Up Ring Sleeve
- 2 = End Ring
- 3 = Gasket
- 4 = Stud, Nut & Washer

Working Pressure = 16bar (water)
6bar (gas)

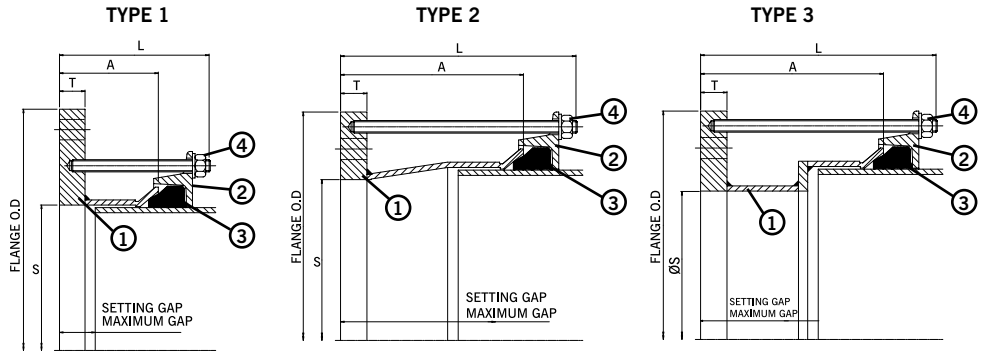

Flange Adaptor PN10

OD Range		Flange Details							Gasket Mould No.	Studs No.-Dia x Length	Setting Gap		Weight (kg)	
Min (mm)	Max (mm)	Nom.	Drilling	Flange Diameter OD (mm)	Flange Bore S (mm)	Flange Thickness T (mm)	Type	Sleeve Length A (mm)			Overall Length L (mm)	Min (mm)		Max (mm)
351.0	368.0	300	PN10	478.0	300.0	18	3	205	298	6002	6-M12 x 290	130	153	36.6
351.0	368.0	350	PN10	505.0	350.0	18	1	120	218	6002	8-M12 x 205	45	68	27.4
351.0	368.0	350	PN10	505.0	370.0	18	1	120	218	6002	8-M12 x 205	45	68	28.9
367.0	384.0	300	PN10	494.0	300.0	18	3	235	313	6097	6-M12 x 305	160	183	41.4
367.0	384.0	350	PN10	505.0	350.0	18	1	120	213	6097	8-M12 x 205	45	68	29.5
374.5	391.5	300	PN10	501.0	300.0	18	3	205	298	1659	6-M12 x 290	130	153	41.2
374.5	391.5	350	PN10	505.0	350.0	18	1	120	213	1659	8-M12 x 205	45	68	29.8
374.5	391.5	350	PN10	505.0	393.5	18	1	120	218	1659	8-M12 x 205	45	68	26.2
374.5	391.5	400	PN10	565.0	393.5	25	1	120	218	1659	8-M12 x 205	45	68	39.4
394.3	411.3	350	PN10	522.0	350.0	18	2	205	303	1766	8-M12 x 290	130	153	37.4
394.3	411.3	350	PN10	505.0	397.5	18	2	205	303	1766	8-M12 x 290	130	153	33.5
394.3	411.3	400	PN10	565.0	400.0	25	1	120	220	1766	8-M12 x 205	45	68	39.3
394.3	411.3	400	PN10	565.0	413.5	25	1	120	220	1766	8-M12 x 205	45	68	37.6
404.8	421.8	350	PN10	532.0	350.0	18	3	235	313	1767	8-M12 x 305	160	183	44.3
404.8	421.8	400	PN10	565.0	400.0	18	1	120	213	1767	8-M12 x 205	45	68	33.4
404.8	421.8	400	PN10	565.0	424.0	18	1	120	218	1767	8-M12 x 205	45	68	31.2
418.2	435.2	400	PN10	565.0	400.0	18	1	120	213	1784	8-M12 x 205	45	68	33.8
418.2	435.2	400	PN10	565.0	437.0	18	1	120	218	1784	8-M12 x 205	45	68	30.4
425.0	442.0	350	PN10	552.0	350.0	18	3	235	313	1662	8-M12 x 305	160	183	48.5
425.0	442.0	400	PN10	565.0	400.0	18	1	120	218	1662	8-M12 x 205	45	68	34.1
425.0	442.0	400	PN10	565.0	444.0	18	1	120	218	1662	8-M12 x 205	45	68	30.0
434.4	451.4	400	PN10	565.0	400.0	18	2	205	298	1768	8-M12 x 290	130	153	40.4
434.4	451.4	400	PN10	565.0	448.0	18	2	205	298	1768	8-M12 x 290	130	153	35.9
447.2	464.2	400	PN10	575.0	400.0	18	2	205	298	1769	8-M12 x 290	130	153	41.9
447.2	464.2	400	PN10	575.0	448.0	18	2	205	298	1769	8-M12 x 290	130	153	37.4
455.0	472.0	400	PN10	582.0	400.0	18	3	240	333	6003	8-M12 x 325	165	188	48.7
455.0	472.0	450	PN10	615.0	450.0	23	1	120	213	6003	10-M12 x 205	45	68	42.0
455.0	472.0	450	PN10	615.0	474.0	23	1	120	218	6003	10-M12 x 205	45	68	38.9
467.0	484.0	400	PN10	594.0	400.0	23	3	205	303	6073	8-M12 x 290	130	153	54.7
467.0	484.0	450	PN10	615.0	450.0	23	1	120	218	6073	10-M12 x 205	45	68	42.4
476.0	493.0	400	PN10	603.0	400.0	23	3	240	338	1770	8-M12 x 325	170	193	60.6
476.0	493.0	450	PN10	615.0	450.0	23	1	120	218	1770	10-M12 x 205	45	68	42.7
476.0	493.0	450	PN10	615.0	495.0	23	1	120	218	1770	10-M12 x 205	45	68	36.7
476.0	493.0	500	PN10	670.0	495.0	25	1	120	218	1770	10-M12 x 205	45	68	49.0
487.3	504.3	400	PN10	615.0	400.0	23	3	245	338	1771	8-M12 x 325	170	193	63.8
487.3	504.3	450	PN10	615.0	450.0	23	2	205	303	1771	10-M12 x 290	130	153	49.8
487.3	504.3	450	PN10	615.0	499.0	23	2	205	303	1771	10-M12 x 290	130	153	43.2

Materials & Relevant Standards

Flange Adaptor Body

Mild Steel to BS EN 10025-2:2004 Grade S275

End Ring

Rolled Steel to BS EN 10025-2:2004 Grade S275

Gasket

EPDM Grade "E" to BS EN 681-1 1996 Type WA WRAS Listed

Bolt Torque / Spanner

Bolt torque - 55-65Nm / Spanner size - A/F 19mm

Studs, Nuts & Washer

Studs - Steel to BS EN ISO 898-1:2009 Property Class 4.8

Nuts - Steel to BS EN 4190:2001 Grade 4

Washer - Stainless Steel to BS 1449:Part 2:1983 Grade 304 S15

Coating

Flange Adaptor Body & End Ring = Rilsan Nylon 11 to WIS 4-52-01 Part 1

Bolts & Nuts = Sheraplex to WIS 4-52-03

Every effort has been made to ensure that the information contained in this publication is accurate at the time of publishing. Crane Ltd assumes no responsibility or liability for typographical errors or omissions or for any misinterpretation of the information within the publication and reserves the right to change without notice.