

MegaFit

Universal pipe couplings

MegaFit

A comprehensive range of couplings to suit the various outside diameters of pipes with nominal bores between DN50 and DN300

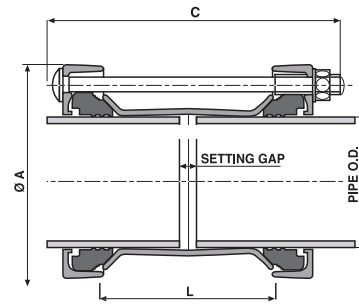

A = End Ring Diameter
T = Sleeve Thickness

| DN | OD Range | | Bolts No x Dia x Length | A | C | Sleeve Length x Thickness (L) x (T) | Setting Gap | | Weight Kg |
|-----|----------|-------|----------------------------|-----|-----|---|-------------|-----|--------------|
| | Min | Max | | | | | Min | Max | |
| 50 | 43.5 | 63.5 | 4 - M12 x 235 | 153 | 242 | 144 x 5 | 18 | 60 | 4.5 |
| 65 | 63.0 | 83.7 | 4 - M12 x 235 | 173 | 242 | 144 x 5 | 18 | 60 | 5.2 |
| 80 | 85.7 | 107.0 | 4 - M12 x 260 | 194 | 267 | 170 x 5 | 18 | 100 | 6.3 |
| 100 | 107.2 | 133.2 | 4 - M16 x 290 | 234 | 300 | 180 x 5 | 18 | 110 | 9.0 |
| 125 | 132.2 | 160.2 | 4 - M16 x 290 | 265 | 300 | 180 x 5.5 | 18 | 110 | 11.3 |
| 150 | 158.2 | 192.2 | 4 - M16 x 340 | 305 | 350 | 213 x 5.5 | 18 | 130 | 15.4 |
| 175 | 192.2 | 226.9 | 4 - M16 x 340 | 346 | 350 | 215 x 7 | 18 | 130 | 21.7 |
| 200 | 218.1 | 252.1 | 4 - M16 x 340 | 371 | 350 | 220 x 8 | 18 | 135 | 24.3 |
| 250 | 266.2 | 300.2 | 6 - M16 x 420 | 419 | 430 | 300 x 8 | 18 | 215 | 34.7 |
| 300 | 315.0 | 349.0 | 6 - M16 x 420 | 468 | 430 | 300 x 8 | 18 | 215 | 39.4 |

MegaDaptor

Flange adaptors designed to join pipes of various materials and outside diameters to flanges of the same nominal size*.

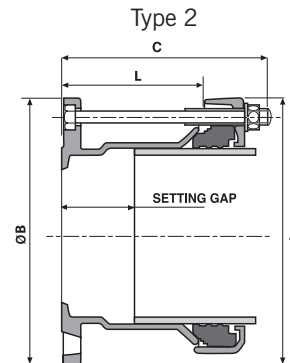
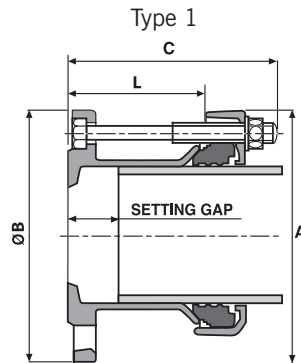

A = End Ring Diameter
B = Flange Diameter
T = Sleeve Thickness

| DN | OD Range | | Flange Nominal | Flange Drilling | Flange Thickness | Bolts No x Dia x Length | A | B | C | Sleeve Length x Thickness (L) x (T) | Setting Gap | | Type | Weight Kg |
|------|----------|-------|-------------------|--------------------|---------------------|----------------------------|-----|-----|-----|---|-------------|-----|------|--------------|
| | Min | Max | | | | | | | | | Min | Max | | |
| 50 | 43.5 | 63.5 | 50 | PN10/PN16 | 17.0 | 4 - M12 x 125 | 153 | 165 | 131 | 80 x 6 | 25 | 35 | 1 | 4.4 |
| 65 | 63.0 | 83.7 | 65 | PN10/PN16 | 17.0 | 4 - M12 x 125 | 173 | 185 | 132 | 80 x 6 | 25 | 35 | 1 | 5.1 |
| 80 | 85.7 | 107.0 | 80 | PN10/PN16 | 17.0 | 4 - M12 x 145 | 194 | 200 | 154 | 100 x 6 | 30 | 60 | 1 | 5.8 |
| 100 | 107.2 | 133.2 | 100 | PN10/PN16 | 18.0 | 4 - M16 x 180 | 234 | 234 | 191 | 130 x 6 | 57 | 85 | 2 | 8.6 |
| 125 | 132.2 | 160.2 | 125 | PN10/PN16 | 18.0 | 4 - M16 x 160 | 265 | 268 | 171 | 111 x 6 | 28 | 65 | 1 | 9.8 |
| 150 | 158.2 | 192.2 | 150 | PN10/PN16 | 18.0 | 4 - M16 x 210 | 305 | 313 | 220 | 150 x 6 | 70 | 100 | 2 | 14.17 |
| 175* | 192.2 | 226.9 | 200 | PN10/PN16 | 18.0 | 4 - M16 x 190 | 346 | 340 | 201 | 132 x 7 | 25 | 80 | 1 | 17.2 |
| 200 | 218.1 | 252.1 | 200 | PN10/PN16 | 18.0 | 4 - M16 x 230 | 371 | 370 | 241 | 180 x 7 | 75 | 130 | 2 | 20.4 |
| 250 | 266.2 | 300.2 | 250 | PN10/PN16 | 20.0 | 6 - M16 x 270 | 419 | 420 | 281 | 212 x 7 | 80 | 160 | 2 | 27.5 |
| 300 | 315.0 | 349.0 | 300 | PN10/PN16 | 21.5 | 6 - M16 x 270 | 468 | 468 | 281 | 211 x 8 | 80 | 160 | 2 | 34.3 |

*DN175 MegaDaptor supplied with DN200 flange.



Tel: +44 (0)1462 443322 • Fax: +44 (0)1462 443311
info@vikingjohnson.com • www.vikingjohnson.com
46-48 Wilbury Way, Hitchin, Hertfordshire, SG4 0UD. United Kingdom

MegaFit

Universal pipe couplings

Material Specification

All MegaFit products are designed and manufactured under quality management systems certified to BS EN ISO 9001, have been tested to the UK Water Regulations Advisory Scheme and conform to the American Water Works Association's standard AWWA/ANSI C.219 for bolted couplings.

Centre Sleeve/End Rings*

SG ductile iron BS EN 1563:1997, EN GJS-450-10

Flange Adaptor Body*

SG ductile iron BS EN 1563:1997, EN GJS-450-10-

Bolts

Steel to BS EN ISO 898-1999 Property Class
Grade 8.8 equivalent DIN 267 - Part 3:Class 8.8

Nuts

Steel to BS EN20898-2:1994
Property Class 8.0

Washers

BS 1449:Pt2:1983 grade 304 S15

Gasket

EPDM compound Grade 'E' to BS EN 681-1:1996 WRAS approved, or nitrile compound to DIN 3535-3

'E' temperature range: -40°C to +90°C. Suitable for water, sewage, many strong and oxidising chemicals, food applications.

Nitrile temperature range: -20°C to +100°C. Suitable for natural gas, petroleum products, low aromatic fuels and compressed air.

(Not suitable for fluctuating temperature, e.g. heating systems).

Coating

Flange adaptor body, centre sleeve, end rings are coated in Rilsan Nylon 11 to WIS 4-52-01 (Part 1).

As standard, all bolts and nuts are Sheraplex coated, which is a compound of zinc sheradising and low friction polymeric coating that meets WIS 4-52-03.

Bolt Torques

| | Nm |
|-----|----------|
| M12 | 55 - 65 |
| M16 | 95 - 110 |

Note:

MegaFit couplings do not resist end load - adequate restraint must be provided.

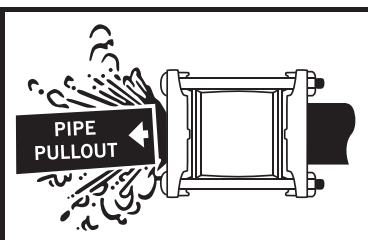

* Materials of construction at the discretion of Viking Johnson. Viking Johnson reserves the right to modify the details in this publication as products and specifications are updated and improved.



VIKING JOHNSON

CRANE

A Crane Co. Company

Tel: +44 (0)1462 443322 • Fax: +44 (0)1462 443311

info@vikingjohnson.com • www.vikingjohnson.com

46-48 Wilbury Way, Hitchin, Hertfordshire, SG4 0UD. United Kingdom

For further information on all Viking Johnson products and services contact our Marketing Department.