

QuickFit Flange Adaptors - Standard Cast

Specifications

QuickFit Flange Adaptor (Standard Cast Product)

Bolt Size	M12 x 115mm Tee Bolt
Setting gap	Recommended - 25mm Max - 45mm
Bolt torque	55-65Nm
Max working	In accordance with flange rating pressure
Expansion/Contraction	5mm
Angularity	3°

- 1 = Body
- 2 = End Ring
- 3 = Gasket
- 4 = Bolts

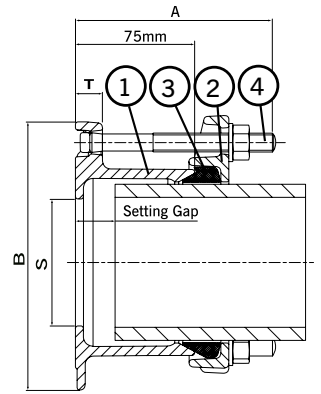

QuickFit Flange Adaptors DO NOT resist end load due to the internal pressure
- adequate external restraint must be provided to prevent pipe pull out.

Size Range (mm)		Flange Detail (mm)		Overall Length A (mm)	S Bore S (mm)	Flange Drilling	Bolt Size No.-Dia x Length	Gasket Mould No.	Weight (kg)
Min	Max	Flange OD (B)	Flange Thickness (T)						
59.5	63.3	161.0	17.0	125.0	50.0	50 PN10,16,25,40	2-M12 x 115	12477/1	2.28
75.3	79.1	181.0	17.0	125.0	65.0	65 PN10,16	2-M12 x 115	12477/5	2.66
88.1	91.9	196.0	17.0	126.0	80.0	80 PN10,16,25,40	4-M12 x 115	12477/7	3.48
95.8	100.2	196.0	17.0	126.0	80.0	80 PN10,16,25,40	4-M12 x 115	12477/10	3.59
107.2	111.0	216.0	17.0	126.0	100.0	100 PN10,16	4-M12 x 115	12477/12	3.91
113.5	120.2	216.0	17.0	126.0	100.0	100 PN10,16	4-M12 x 115	12477/15	4.03
138.9	142.7	246.0	17.0	126.0	125.0	125 PN10,16	4-M12 x 115	12477/19	4.71
158.2	162.0	284.0	17.0	126.0	150.0	150 PN10,16	4-M12 x 115	12477/21	5.76
167.5	172.3	284.0	17.0	126.0	150.0	150 PN10,16	4-M12 x 115	12477/24	5.87
192.9	196.7	339.0	20.0	126.0	199.0	200 PN10,16	4-M12 x 115	12477/26	8.43
218.3	224.4	339.0	20.0	126.0	200.0	200 PN10,16	4-M12 x 115	12477/29	8.49
272.2	276.5	405.0	20.0	129.0	250.0	250 PN10,16	6-M12 x 115	12477/34	11.38
323.1	328.6	455.0	20.0	129.0	300.0	300 PN10,16	6-M12 x 115	12477/37	13.04

Test pressure = 1.5 x working pressure

Tied Flange Adaptor

The design of the new QuickFit flange adaptor is such that there is sufficient clearance to allow tie rods (used to restrain them) to pass over without the need for notching.

Materials & Relevant Standards

Flange Adaptor Body and End Rings

Ductile Iron to BS EN1563: Symbol EN-GJS-450-10

Gaskets

Standard: EPDM to BS EN681-1, TYPE WA, WC Nitrile to BS EN682:
Type G Other grades are available - contact Viking Johnson for details

Tee Bolts/Bolts

Standard: Steel to BS EN ISO 898-1: property class 4.8
Option: Stainless Steel to BS EN ISO 3506-1: grade A4
property class 50

Nuts/Washers

Nuts - Standard: Steel to BS EN 20898-2: property class 8
Option: Stainless Steel to BS EN ISO 3506-2: grade A4
property class 80

Washers - Stainless Steel to BS1449:PART 2: GRADE 304S15

Coatings

Flange adaptor body and end rings coated with:
Standard: Rilsan Nylon 11 to WIS 4-52-01 Part 1
Other coatings available: Scotchkote, Primer, Galvanised
Tee bolts, CDX bolts and nuts coated with
Standard: Sheraplex to WIS 4-52-03

Every effort has been made to ensure that the information contained in this publication is accurate at the time of publishing. Crane Ltd assumes no responsibility or liability for typographical errors or omissions or for any misinterpretation of the information within the publication and reserves the right to change without notice.