

Large Diameter Flange Adaptors OD355 - 1016mm to BS EN 1092-1 PN10 Drilling

Specifications

L = Distance back from end of pipe that must be rounded, meet tolerances, and free from any wrapping to ensure correct assembly.

Flange Adaptor Type	Flange Adaptor Section	Sleeve Length S (mm)	Distance L (mm)	Setting Gap X (mm)		Bolt Details		
				Min.	Max.	Bolt Dia.	Length (mm)	Torque (Nm)
Standard Sleeve	LO2	73	150	25	50	M12	140	55 - 65
Long Sleeve	LO3	123	200	25	100	M12	180	55 - 65
Standard Sleeve	YF2	87	150	32	76	M16	160	95 - 120
Long Sleeve	YF3	123	200	32	115	M16	190	95 - 120
Standard Sleeve	A2E	87	150	32	76	M16	160	95 - 120
Long Sleeve	A2H	125	200	32	115	M16	190	95 - 120
Standard Sleeve	XSXG	254	200	57	117	M16	400	95 - 120

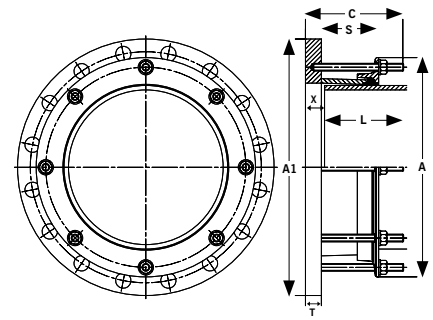

NOTES

- General** Viking Johnson manufacture flange adaptors to any pipe OD and flange drilling. If the product required is not shown in any of our tables please contact Viking Johnson who can provide the relevant information.
- Pressure** Working pressure is in accordance with the flange drilling. Site test pressure is 1.5x working pressure.
- End Restraint** Dedicated flange adaptors DO NOT resist end load due to the internal pressure - adequate external restraint must be provided by either anchoring the pipework or use of tie rods to restrain the flange adaptor and prevent pipe pull out.
- Tie Rods** When using tie rods to provide restraint, depending on the pipe OD & flange drilling the flange adaptor end ring may need to be notched to allow the tie rod to pass over. The table below provides details on :-
 A) Those products that do not require notching (i.e. there is no interference between the tie rods and end ring) - indicated by "Not Rqd."
 B) Those products where there is interference between the tie rod and end ring and do require notching, with the number of notches provided as standard indicated.
- Tie Rod Yield Strength** The number of notches indicated assumes the use of tie rods with a minimum yield strength of 725 N/mm².
 If tie rods with a lower yield strength are used, then depending on the working pressure an increased number than that specified in the table may be required; in this situation please advise Viking Johnson of the number of notches and we will accommodate your requirements.

Pipe OD (mm)	Pipe Material	Flange Drilling BS EN 1092-1		Tolerance on Pipe OD for Distance L		Gasket Mould No.	No. Notches in End Ring if Required	Flange Adaptor Section Type		Flange Adaptor Studs No. x Dia	Weight (kg)		Dimensions						Flange Adaptor Studs Length	
		Nominal	Drilling	(mm) +	(mm) -			Standard Sleeve	Long Sleeve		Standard Sleeve	Long Sleeve	Diameter A (mm)	Flange OD A1 (mm)	Flange Thickness T (mm)	Flange Bolts No. x Dia	Overall C Standard Sleeve (mm)	Overall C Long Sleeve (mm)	Standard Sleeve	Long Sleeve
355.6	Steel & uPVC	350	PN10	1.6	1.6	J51LS	4	L02	L03	8 x M12	22.8	26.2	446	505	18	16 x M20	148	188	140	180
358.6	Coated Steel	350	PN10	1.6	1.6	J51LS	4	L02	L03	8 x M12	22.6	26.1	450	505	18	16 x M20	148	188	140	180
378	Ductile Iron	350	PN10	2.7	3.5	J52LS	8	L02	L03	8 x M12	21.3	24.9	469	505	18	16 x M20	148	188	140	180
406.4	Steel & uPVC	400	PN10	1.6	1.6	J53LS	4	L02	L03	8 x M12	26.3	30.2	497	565	18	16 x M24	148	188	140	180
409.4	Coated Steel	400	PN10	1.6	1.6	J53LS	4	L02	L03	8 x M12	26.1	30.0	500	565	18	16 x M24	148	188	140	180
429	Ductile Iron	400	PN10	2.8	4.0	J54LS	8	L02	L03	8 x M12	24.5	28.6	520	565	18	16 x M24	148	188	140	180
457	Steel & uPVC	450	PN10	1.6	1.6	J55LS	5	L02	L03	10 x M12	33.5	37.9	548	615	23	20 x M24	153	193	140	180
460	Coated Steel	450	PN10	1.6	1.6	J55LS	5	L02	L03	10 x M12	33.2	37.6	551	615	23	20 x M24	153	193	140	180
480	Ductile Iron	450	PN10	2.9	4.0	J56LS	10	L02	L03	10 x M12	30.7	35.2	571	615	23	20 x M24	153	193	140	180
508	Steel & uPVC	500	PN10	1.6	1.6	J57LS	5	L02	L03	10 x M12	37.7	42.5	598	670	23	20 x M24	153	193	140	180
511	Coated Steel	500	PN10	1.6	1.6	J57LS	5	L02	L03	10 x M12	37.3	42.1	602	670	23	20 x M24	153	193	140	180
532	Ductile Iron	500	PN10	3.0	4.0	J58LS	10	L02	L03	10 x M12	34.3	39.3	624	670	23	20 x M24	153	193	140	180
610	Steel & uPVC	600	PN10	1.6	1.6	J60LS	5	L02	L03	10 x M12	45.9	51.6	700	780	23	20 x M27	153	193	140	180
613	Coated Steel	600	PN10	1.6	1.6	J60LS	5	L02	L03	10 x M12	45.4	51.1	703	780	23	20 x M27	153	193	140	180
635	Ductile Iron	600	PN10	3.2	4.5	J61LS	10	L02	L03	10 x M12	41.6	47.5	726	780	23	20 x M27	153	193	140	180
711	Steel	700	PN10	1.6	1.6	J63LS	Not Rqd.	L02	L03	12 x M12	56.1	62.7	802	895	23	24 x M27	153	193	140	180
714	Coated Steel	700	PN10	1.6	1.6	J63LS	6	L02	L03	12 x M12	55.6	62.2	805	895	23	24 x M27	153	193	140	180
738	Ductile Iron	700	PN10	3.4	4.5	J63LS	12	L02	L03	12 x M12	50.8	57.6	830	895	23	24 x M27	153	193	140	180
813	Steel	800	PN10	1.6	1.6	J65LS	Not Rqd.	L02	L03	12 x M12	68.2	75.7	903	1015	23	24 x M30	153	193	140	180
816	Coated Steel	800	PN10	1.6	1.6	J65LS	Not Rqd.	L02	L03	12 x M12	67.6	75.1	906	1015	23	24 x M30	153	193	140	180
842	Ductile Iron	800	PN10	1.0	4.5	J65LS	12	L02	L03	12 x M12	62.2	69.9	931	1015	23	24 x M30	153	193	140	180
914	Steel	900	PN10	1.6	1.6	J67LS	Not Rqd.	L02	L03	14 x M12	79.8	88.2	1005	1115	25	28 x M30	155	195	140	180
916	Coated Steel	900	PN10	1.6	1.6	J67LS	Not Rqd.	L02	L03	14 x M12	79.3	87.7	1007	1115	25	28 x M30	155	195	140	180
945	Ductile Iron	900	PN10	1.0	5.0	J70LS	14	YF2	YF3	14 x M16	89.3	97.5	1054	1115	25	28 x M30	169	199	160	190
1016	Steel	1000	PN10	1.6	1.6	J71LS	7	YF2	YF3	14 x M16	112.4	121.2	1125	1230	25	28 x M33	169	199	160	190

Every effort has been made to ensure that the information contained in this publication is accurate at the time of publishing. Crane Ltd assumes no responsibility or liability for typographical errors or omissions or for any misinterpretation of the information within the publication and reserves the right to change without notice.