

Dismantling Joint DN350 to DN2400 (PN16)

Specifications

Note: Maximum Longitudinal Adjustment
= Maximum Length – Minimum Length

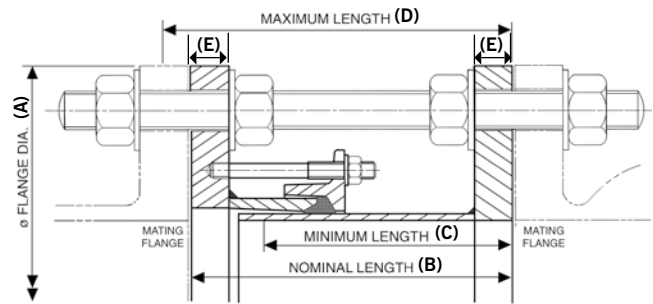

Dismantling Joint

Flange Details				Flange To Flange Details			Tie Rod Details					
Nom	Drilling	Flange Thickness	Flange OD	Nominal Length	Minimum Length	Maximum Length	Steel Tie Rod			Stainless Steel Tie Rod		
		E (mm)	A (mm)	B (mm)	C (mm)	D (mm)	Dia x Length (mm)	No.	Total Weight of DJ (kg)	Dia x Length (mm)	No.	Total Weight of DJ (kg)
350	PN16	18	520	295	270	320	M24 x 450	4	63.4	M24 x 450	4	63.4
400	PN16	18	580	295	270	320	M27 x 460	4	75.2	M27 x 460	4	75.2
450	PN16	23	640	300	275	325	M27 x 470	5	99.0	M27 x 470	5	99.0
500	PN16	23	715	300	275	325	M30 x 480	5	121.0	M30 x 480	5	121.0
550	PN16	23	775	300	275	325	M30 x 490	5	134.0	M30 x 490	5	134.0
600	PN16	23	840	300	275	325	M33 x 500	5	154.0	M33 x 500	5	154.0
650	PN16	23	860	300	275	325	M33 x 510	6	153.0	M33 x 510	6	153.0
700	PN16	23	910	300	275	325	M33 x 520	6	162.0	M33 x 520	6	162.0
750	PN16	23	970	300	275	325	M33 x 530	6	177.0	M33 x 530	8	182.0
800	PN16	23	1025	300	275	325	M36 x 540	6	184.0	M36 x 540	8	190.5
900	PN16	25	1125	307	277	337	M36 x 570	7	232.0	M36 x 570	10	251.5
1000	PN16	25	1255	307	277	337	M39 x 590	7	282.0	M39 x 590	10	306.5
1100	PN16	38	1355	320	290	350	M39 x 610	8	406.0	M39 x 610	12	438.0
1200	PN16	38	1485	320	290	350	M45 x 640	8	505.0	M45 x 640	10	529.0
1300	PN16	38	1585	320	290	350	M45 x 650	8	533.0	M45 x 650	12	582.0
1400	PN16	38	1685	320	290	350	M45 x 660	9	583.0	M45 x 660	14	644.0
1500	PN16	38	1820	320	290	350	M52 x 690	9	760.0	M52 x 770	12	829.0
1600	PN16	38	1930	320	290	350	M52 x 710	10	850.0	M52 x 800	12	903.0
1800	PN16	38	2130	320	290	350	M52 x 730	11	962.0	M52 x 810	16	1,075.0
2000	PN16	60	2345	462	412	512	M56 x 930	12	1,662.0	M56 x 1020	18	1,899.0
2200	PN16	60	2555	462	412	512	M56 x 950	13	1,871.0	M56 x 1040	20	2,145.0
2400	PN16	60	2765	462	412	512	M56 x 980	16	2,144.0	M56 x 1070	24	2,468.0

Materials & Relevant Standards

Flange Drilling

BS EN1092-1 (formerly BS4504), ISO7005

Fabricated Flange Adaptor

Body - Rolled Steel to BS EN 10025-2: Grade S275

End Rings/Sleeve - Rolled Steel to BS EN 10025-2: Grade S275 or Rolled Steel to BS EN 10025-2: Grade S355 (depending on section)

Flanged Spigot

Flange - Rolled Steel to BS EN 10025-2: Grade S275
Spigot - Steel Tube to BS10216-1: Grade P265TR1 or Rolled Steel to BS EN 10025-2: Grade S275

Gaskets

BS EN681-1: Type WA WRAS listed

Steel Tie Rods & Nuts

Tie Rods - BS EN10269: Name 42CrMo4 (Yield 725N/mm²) (formerly MB7)
Nuts - BS EN20898-2: Property Class 8.0

Stainless Steel Tie Rods & Nuts

Tie Rods - Stainless Steel to BS EN3506-1: Grade A2/A4 Property Class 70 (Yield 450N/mm²)
Nuts (sizes up to & including M48) 4 per Tie Rod - Stainless Steel to BS EN3506-2: Grade A2/A4 Property Class 80
Nuts (sizes over M48) 6 per Tie Rod - Stainless Steel to BS EN3506-2: Grade A2/A4 Property Class 50

Studs/Nuts/Washers

Studs - Steel to BS EN ISO898-1: Property Class 4.8

Nuts - Steel to BS4190: Grade 4

Washers - Stainless Steel to BS1449:Part 2: Grade 304S15

Coatings (Others available on request)

Fabricated Flange Adaptor - Rilsan Nylon 11
Flanged Spigot - Rilsan Nylon 11
End Ring - Rilsan Nylon 11
Studs/Nuts - Sheraplex to WIS 4-52-03
Steel Tie Rods/Nuts - Zn3 Zinc coated

Every effort has been made to ensure that the information contained in this publication is accurate at the time of publishing. Crane Ltd assumes no responsibility or liability for typographical errors or omissions or for any misinterpretation of the information within the publication and reserves the right to change without notice.