

Unique

# AquaGrip

Couplings & Flange Adaptors  
For Polyethylene Pipe Connections



**VIKING JOHNSON™**

PIONEERS IN PIPE SOLUTIONS

**CRANE**

BUILDING SERVICES & UTILITIES



# A High Performance Polyethylene Pipe Jointing System

The AquaGrip range was developed in response to demand for a simple, high performance end load restraint (Type 1) mechanical method of joining polyethylene pipe. AquaGrip products are designed to support and grip PE pipe to prevent pipe collapse and pullout.

### Easy & Safe to Fit

The range requires no special skills or complicated tools to fit, a suitably calibrated torque wrench is the only specialist tool required. The ability to rotate the flange bolt holes and the lightweight, compact design provide easier handling and quicker installation.

### On-the-spot Repairs

Another key benefit of the AquaGrip range is 'all-weather installation'. It can be installed under wet conditions without shelters, and even under water. It is ideal for on-the-spot repairs - no need for fusion joining equipment when unexpected problems arise!

### High Performance

Once fitted the product range offers axial restraint and is designed and tested to meet the full Type 1 performance requirements of WIS 4-24-01 in all sizes up to 450mm. Full Type 2 performance is achieved on larger sizes. It is designed to equal or exceed the pressure capabilities of MDPE (PE80) and HDPE (PE100) pipe and has total corrosion protection with Rilsan Nylon coated body and clamp bands.

Flange Adaptors  
OD 225mm & Larger

Flange Adaptors  
OD up to 180mm

Couplings OD 63mm to 180mm

Pipe Material



# AquaGrip Coupling & Flange Adaptor up to 180mm

## Product Design Benefits

### Exceptional Grip

The combination of the acetal grippers and separate internal support liner gives AquaGrip an end load gripping capability of Type 1 to WIS 4-24-01.

This means that the joint is stronger than the PE pipe itself.



### Designed to Last

The sleeve or body are fully coated in black Rilsan Nylon 11 which has excellent resistance to impact, abrasion, weathering and chemicals as well as good thermal stability and flexibility to accommodate for rough site handling. It is also WRAS listed.

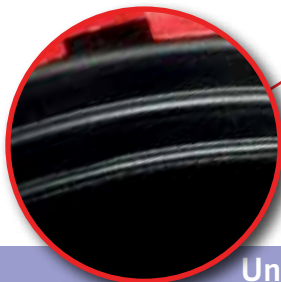
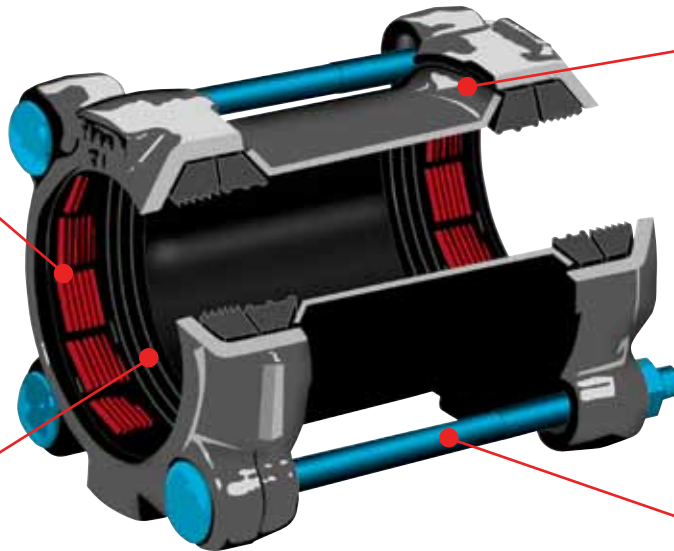

### Unique Gasket

The EPDM gasket (Compound 80 IRHD Grade E) is suitable for water and sewage applications between a temperature range of -10°C to +40°C.

### Corrosion Resistance

Sheraplex coated nuts & bolts offer excellent corrosion resistance and eliminates galling of coating in threads allowing repeated dismantling and installation of products if required.



## Customer Benefits

- Slip-on coupling without centre stop or obstruction making it easier to make repairs to existing pipelines.
- No need to dismantle products to install.
- Same size bolt throughout range means just one torque wrench for all pipe sizes.
- Substantial axial pipe adjustment up to 50mm - ideal for making pipe and valve insertions into existing lines. No need for precise cutting of the pipes or for machined pipe ends.
- Versatile range. Straight couplings for simple, convenient repairs, or new lay connections. Flange adaptors to introduce valves and flanged fittings or connect to existing flanged pipework.

- Supplied complete with liners for PE pipes.
- AquaGrip has been tested and found to comply with the requirements of the Water Supply (Water Fittings) Regulations 1999 for England and Wales, the Water Byelaws 2000 Scotland and the Water Regulations Northern Ireland.
- Flange adaptors and straight couplings designed to the full Type 1 performance requirements of WIS 4-24-01.



Flange Adaptor

# AquaGrip Flange Adaptor 225mm to 1600mm

## Product Design Benefits

### Exceptional End Restraint

Uniquely designed clamp locks onto the anchoring shoulder, providing maximum end load restraint.



### Reliable Seal

The flanged body incorporates an internal support liner which carries the double ridged gasket(s) that seals on the inside of the PE pipe. The inside of the pipe is well protected from casual on-site damage, so the seal remains secured.

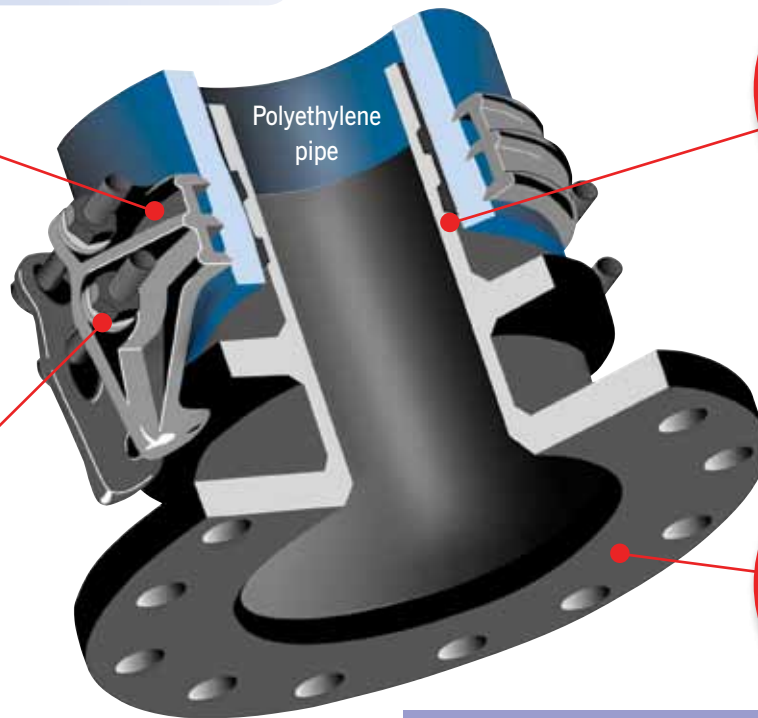

### Corrosion Resistance

Bolts, nuts and washers are plated in zinc, and then Grey Flurene® 177, a low friction coating which offers excellent corrosion resistance.

### External Coating

The body, clamp band and liner are fully coated in Black Rilsan Nylon 11 which has excellent resistance to impact, abrasion, weathering and chemicals as well as good thermal stability and flexibility to accommodate for rough site handling. It is WRAS listed.



## Customer Benefits

- ▶ Large size flange adaptors seal on the inside of the pipe ensuring a quick and reliable seal and greater customer confidence.
- ▶ Available in sizes up to 1600mm
- ▶ Connects to other types of pipe via a flange connection, ideal for replacing damaged pipe lengths with new pipe or introducing flanged fittings, such as metal valves, into a polyethylene pipeline.
- ▶ AquaGrip is available with reduced bore flanges which can reduce valve fitting costs e.g. 315mm pipe OD x 250mm flange, 500mm pipe OD x 450mm flange.
- ▶ Ideal for structural lining in conjunction with mains refurbishment techniques such as Swage-Line® RollDown® and Die Draw®.
- ▶ Uniquely designed clamp bands lock onto the anchoring shoulder, providing maximum end restraint.
- ▶ Tackles problem of misshapen polyethylene pipe ends.
- ▶ Generous cutting tolerance can compensate for cutting inaccuracy (40mm minimum tolerance).
- ▶ UK Water Regulations Advisory Scheme (WRAS) approved and designed to meet the performance requirements of WIS 4-24-01 (Type 1 performance to WIS 4-24-01 up to 450mm SDR 11, other sizes / SDR's minimum Type 2).

Please note that these products may require the use of heating mats. Please contact the Marketing Department on +44 (0) 1462 443322 for details.

Sri Lanka - Wakwella

# Laying Transmission Main

AquaGrip Flange Adaptor - DN500

Couplings & Flange Adaptors

PE Solutions

## Project

The transmission main runs from Wakwella Treatment Plant to Beak Reservoir. The project has been funded by the American Red Cross and will see replacement of existing old asbestos cement pipeline with a new PE network. The new PE pipeline needs to connect to ductile iron flanges at culverts and valve chambers - large diameter AquaGrip is ideally suited.

## Client

National Water Supply & Drainage Board

## Consultant

Integrated Development Consultants

## Distributor

Lanka Development Network

# AquaGrip Couplings & Flange Adaptors up to 180mm

## Specifications

AquaGrip couplings and flange adaptors up to 180mm are currently manufactured for SDR17 and SDR11 PE pipe. SDR26 is also available on AquaGrip couplings 125mm and 160mm.

AquaGrip coupling assembly joins PE pipe to PE pipe

Pipe OD	Dimensions (mm)		No. of Bolts	Bolts size (mm)	Gasket Mould No.	Weight (kg)
	A	C				
63	144	208	2	M12x200	6001	2.4
90	167.5	208	4	M12x200	1785	3.8
110	188	208	4	M12x200	1786	5.4
125	203	208	4	M12x200	1787	5.8
160	240	223	8	M12x215	1788	9.0
180	257.5	223	8	M12x215	1789	9.8

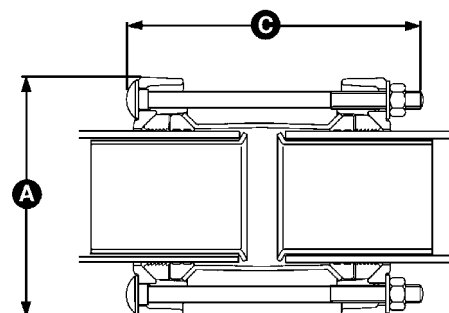

AquaGrip flange adaptor assembly joins PE pipe to flanged equipment

Pipe OD	Dimensions (mm)		No. of T-Bolts	T-Bolt size (mm)	Flange specification nom (mm)	Gasket Mould No.	Weight (kg)
	A	C					
63	200	123	2	M12x115	50/80 PN10/16	6001	3.6
90	200	123	4	M12x115	80 PN10/16	1785	3.8
110	220	123	4	M12x115	100 PN10 & 16	1786	4.2
125	220	123	4	M12x115	100 PN10 & 16	1787	4.3
160	285	129	8	M12x115	150 PN10 & 16	1788	8.1
180	285	129	8	M12x115	150 PN10 & 16	1789	8.5

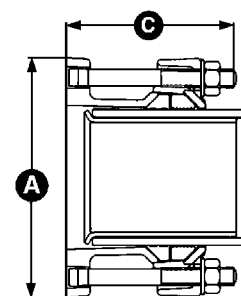

## Materials & Relevant Standards

### End rings/Flange adaptor body

SG iron to BS EN 1563 Symbol EN-GJS-450-10.

### Centre sleeve/Liners

Mild steel to BS EN 10025 Grade S 275.

### Bolts

To BS EN ISO 898-1 Property Class 4.8.

### Nuts

To BS 4190 Grade 4.

### Washers

Stainless steel - BS 1449: PT2 Grade 304 S 15

### Gripper

Acetal copolymer Grade M90 or equivalent.

### Gasket

EPDM compound 80 IRHD Grade 'E' to BS EN 681-1 Type WA. Temperature range: -10°C to +40°C. Suitable for water and sewage applications. (Not suitable for fluctuating temperature, i.e. heating systems.) WRAS listed.

### Coating

Flange adaptor body, centre sleeve and end rings are coated in Rilsan Nylon 11. Rilsan complies with WIS 4-52-01

Part 1. Bolts: Blue Sheraplex followed by dry film lubricant (Ilex).

### Performance criteria

WRAS listed and designed to meet the Full Type 1 performance requirements of WIS 4-24-01.

### Bolt torque required

Blue Sheraplex: 40-50lb.ft (55-65Nm.)

### Pressure rating

16 bar

Every effort has been made to ensure that the information contained in this publication is accurate at the time of publishing. Crane Ltd assumes no responsibility or liability for typographical errors or omissions or for any misinterpretation of the information within the publication and reserves the right to change without notice.

# AquaGrip Flange Adaptor 225mm to 1600mm

## Specifications

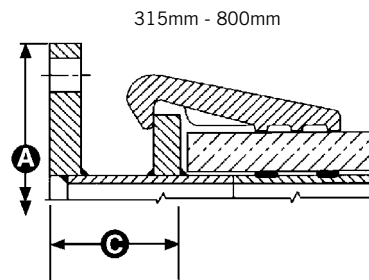
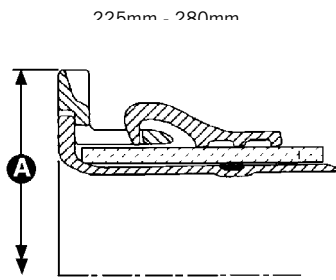

Note:

\*SDR = Standard Dimensional Ratio

= Pipe OD

Wall Thickness

\*\* The chart introduces the popular flange drillings. Other drillings may be possible - contact Viking Johnson for further details

Pipe OD	SDR Rating *				Flange Drilling **	Pressure Rating	Dimensions		No. of Bolts	Bolt Size	Weight (approx) (kg)	Gasket - 13022/			
	11	17/17.6	21	26/33			A (mm)	C (mm)				11	17/17.6	21	26/33
225	✓	✓	✓	✓	200	PN16	340	-	4	M16x130	15	1763	1685	1685	1685
250	✓	✓	✗	✓	200	PN16	340	-	4	M16x130	24	1655	1686	1686	1686
250	✓	✓	✓	✓	250	PN16	405	-	4	M16x130	23	1685	1686	1686	1686
280	✓	✓	✓	✓	250	PN16	405	-	4	M16x130	32	1686	1713	1713	1687
315	✓	✓	✓	✓	250	PN16	405	170	4	M20x120	48	4	24	6	6
355	✓	✓	✓	✓	300	PN16	460	138	6	M20x120	65	6	32	34	8
355	✓	✓	✓	✓	350	PN16	520	138	6	M20x120	65	6	32	34	8
400	✓	✓	✓	✓	400	PN16	580	134	9	M20x120	95	34	9	25	25
450	✓	✓	✓	✓	400	PN16	580	134	9	M27x150	160	25	11	12	12
450	✓	✓	✓	✓	450	PN16	640	134	9	M27x150	186	25	11	12	12
500	✓	✓	✓	✓	400	PN16	580	175	9	M27x150	169	11	26	27	13
500	✓	✓	✓	✓	450	PN16	640	134	9	M27x150	169	11	26	27	13
500	✓	✓	✓	✓	500	PN16	715	134	9	M27x150	199	11	26	27	13
560	✓	✓	✓	✓	450	PN16	640	235	12	M27x150	200	27	28	14	14
560	✓	✓	✓	✓	500	PN16	715	180	12	M27x150	248	27	28	14	14
630	✓	✓	✓	✓	600	PN16	840	220	12	M27x150	311	14	15	15	29
710	✗	✓	✓	✓	700	PN16	910	310	12	M27x150	311	-	16	35	35/36
800	✗	✓	✓	✓	700	PN16	910	270	15	M27x150	470	-	31	18	19
800	✗	✓	✓	✓	800	PN16	1025	270	15	M27x150	497	-	31	18	19
900	✗	✓	✓	✓	900	PN16	1125	Contact Viking Johnson	15	M33x160	800	-	36	20	37
1000	✗	✓	✓	✓	1000	PN16	1255		18	M33x160	1107	-	20	20	20
1200	✗	✗	✗	✓	1200	PN16	1485		18	M33x180	1127	-	-	-	22
1400	✗	✗	✗	✓	1400	PN16	1685		18	M33x180	1582	-	-	-	23
1600	✗	✗	✗	✓	1600	PN16	1930	24	M33x180	1808	-	-	-	-	-

- ✓ Product installation requires heating mats at all temperatures.
- ✓ Product installation requires heating mats if temperature of bore to the pipe falls below -5°C.
- ✗ PE pipe wall too thick – do not have a product.

## Materials & Relevant Standards

### Flange adaptor body

280mm and below: SG iron to BS EN 1563 Symbol EN-GJS-450-10.  
315mm and above: mild steel to BS EN10025 Grade S275.

### Clamp band

SG iron (225mm to 800mm) to BS EN 1563 Symbol EN-GJS-450-10.  
Mild steel to BS EN10025 Grade S275 (900mm to 1600mm).

### Liner

(225 - 280mm sizes): aluminium to BS1490 Grade LM 27M.

### Gaskets

70 IRHD EPDM to BS EN 681-1 Type WA. WRAS listed.

### Coatings

Flange adaptor body, clamp bands and liners are coated in Rilsan Nylon 11 (Black), WRAS listed.

Bolts and nuts and washers are zinc plated followed by Grey Flurene® 177.

### Please note:

This product must be tightened to the required torque range:

- M16 bolts 70 - 80lbf.ft ( 95 - 110Nm.)
- M20 bolts 140 - 160lbf.ft (190 - 215Nm.)
- M27 bolts 260 - 300lbf.ft (350 - 405Nm.)
- M33 bolts 500 - 550lbf.ft (675 - 750Nm.)

### Performance criteria

Designed and listed to meet the full Type 1 performance requirements of WIS 4-24-01 in all sizes up to 450mm.

For confirmation of other sizes please contact our Marketing Department.

Every effort has been made to ensure that the information contained in this publication is accurate at the time of publishing. Crane Ltd assumes no responsibility or liability for typographical errors or omissions or for any misinterpretation of the information within the publication and reserves the right to change without notice.

France - Marseille

# Martigues Thermal Power Plant

AquaGrip Flange Adaptor - DN350



## Project

The Martigues power plant is located on the shores of the Mediterranean 30km from Marseille. The existing power plant comprises of 4 oil fired 250mw units. Two of these are to be transformed into state of the art gas fired combined cycle units.

## Client

EDF

## Contractor

Cari TP Nice

## Distributor

Glynwed France





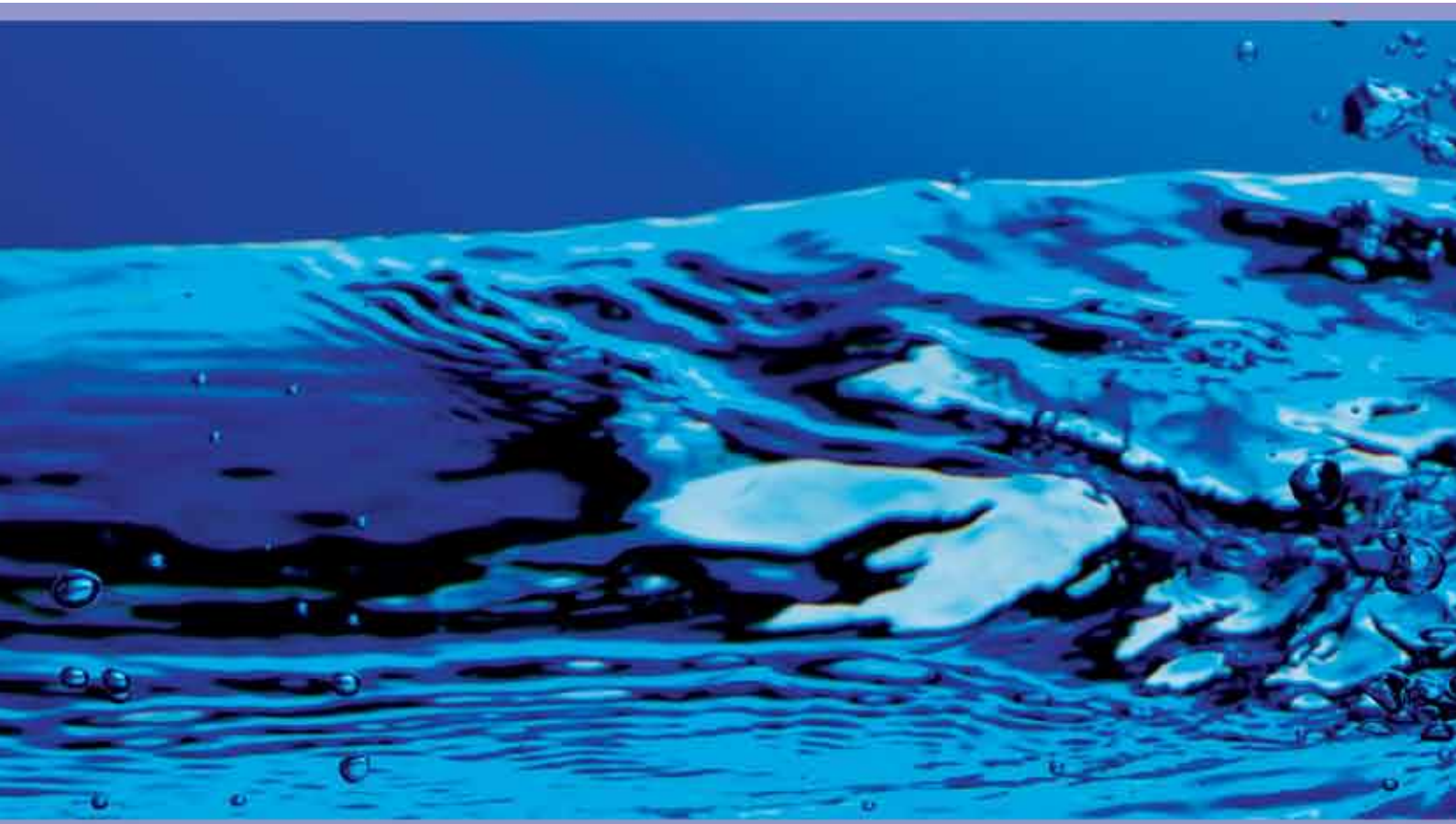

46-48 WILBURY WAY  
HITCHIN, HERTFORDSHIRE  
SG4 0UD. UNITED KINGDOM  
TELEPHONE: +44 (0)1462 443322  
FAX: +44 (0)1462 443311  
EMAIL: [info@vikingjohnson.com](mailto:info@vikingjohnson.com)

[www.vikingjohnson.com](http://www.vikingjohnson.com)

*Every effort has been made to ensure that the information contained in this publication is accurate at the time of publishing. Crane Ltd assumes no responsibility or liability for typographical errors or omissions or for any misinterpretation of the information within the publication and reserves the right to change without notice.*



ISO 14001 • EMS 51874



ISO 9001 • FM 00311



To visit our Video Library go to:  
[www.youtube.com/user/CraneBSU](http://www.youtube.com/user/CraneBSU)

- Designed and manufactured under quality management systems in accordance with BS EN ISO 9001.
- Environmental Management System accredited to ISO 14001.
- For full terms and conditions, please visit our website.

DR7976\_04\_2015

PIONEERS IN PIPE SOLUTIONS



[www.cranesbu.com](http://www.cranesbu.com)

