

QuickFit Couplings

Specifications

QuickFit Coupling

Bolt size	M12 x 180mm CDX	1 = Centre Sleeve
Setting gap	Recommended - 20mm Max - 40mm	2 = End Ring
Bolt torque	55-65Nm	3 = Gasket
Expansion/Contraction	10mm	4 = Bolts
Angularity	6°	

QuickFit Couplings DO NOT resist end load due to the internal pressure - adequate external restraint must be provided to prevent pipe pull out.

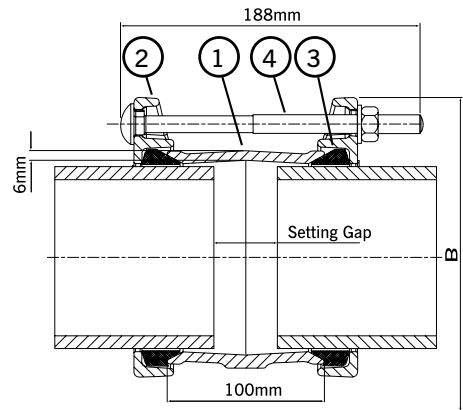

Size Range (mm)		Working Pressure (bar)	End Ring OD B (mm)	Bolt Size No.-Dia x Length	Gasket Mould No.	Weight (kg)
Min	Max					
47.9	51.3	46.6	136.0	2-M12 x 180	12477/41	2.22
59.5	63.3	46.6	148.0	2-M12 x 180	12477/1	2.51
75.3	79.1	46.6	164.0	2-M12 x 180	12477/5	2.89
88.1	91.9	46.6	177.0	4-M12 x 180	12477/7	3.81
95.8	100.2	46.6	185.0	4-M12 x 180	12477/10	4.00
107.2	111.0	46.6	196.0	4-M12 x 180	12477/12	4.26
113.5	120.2	46.6	205.0	4-M12 x 180	12477/15	4.48
138.9	142.7	44	228.0	4-M12 x 180	12477/19	5.02
158.2	162.0	38.8	254.0	4-M12 x 180	12477/21	6.32
167.5	172.3	36.9	264.0	4-M12 x 180	12477/24	6.59
192.9	196.7	32.2	292.0	4-M12 x 180	12477/26	8.06
218.3	224.4	35.8	319.0	4-M12 x 180	12477/29	8.89
272.2	276.5	34.8	372.0	6-M12 x 180	12477/34	11.15
323.1	328.6	29.5	424.0	6-M12 x 180	12477/37	12.76

Site Test pressure = 1.5 x working pressure

Materials & Relevant Standards

Centre Sleeve and End Rings

Ductile Iron to BS EN1563: Symbol EN-GJS-450-10

Gaskets

Standard: EPDM to BS EN681-1, TYPE WA, WC Nitrile to BS EN682:

Type G Other grades are available - contact Viking Johnson for details

Tee Bolts/Bolts

Standard: Steel to BS EN ISO 898-1: property class 4.8

Option: Stainless Steel to BS EN ISO 3506-1: grade A4 property class 50

Nuts/Washers

Nuts - Standard: Steel to BS EN 20898-2: property class 8

Option: Stainless Steel to BS EN ISO 3506-2: grade A4 property class 80

Washers - Stainless Steel to BS1449:PART 2: GRADE 304S15

Coatings

Centre sleeve and end rings coated with:

Standard: Rilsan Nylon 11 to WIS 4-52-01 Part 1

Other coatings available: Scotchkote, Primer, Galvanised

Tee bolts, CDX bolts and nuts coated with Standard Sheraplex to WIS 4-52-03

Every effort has been made to ensure that the information contained in this publication is accurate at the time of publishing. Crane Ltd assumes no responsibility or liability for typographical errors or omissions or for any misinterpretation of the information within the publication and reserves the right to change without notice.