

MegaDaptor Flange Adaptors

Specifications

Flange adaptors designed to join pipes of various materials and outside diameters to flanges of the same nominal size*.

Working Pressure = 16bar (water)
6bar (gas)

A = End Ring Diameter
B = Flange Diameter
C = Overall Length
L = Body Length
T = Sleeve Thickness

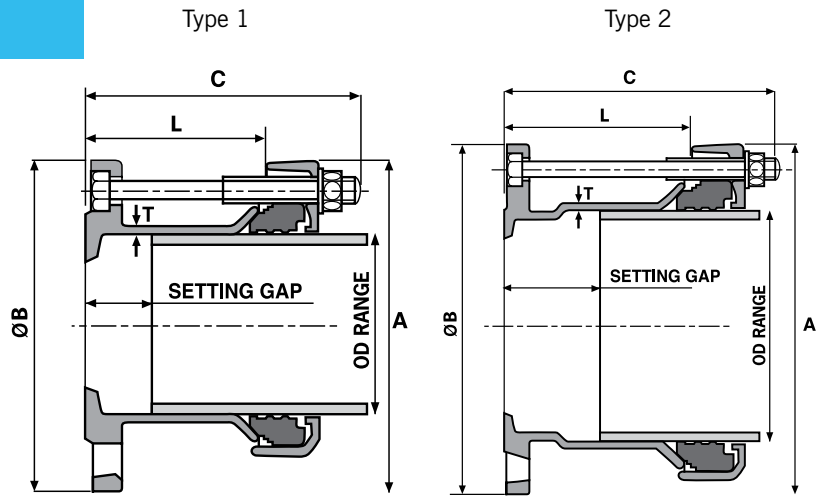

Flange Adaptor

DN	OD Range (mm)		Flange Nominal	Flange Drilling	Flange Thickness (mm)	Bolts No.-Dia x Length	A (mm)	B (mm)	C (mm)	Sleeve Length x Thickness (L) x (T)	Setting Gap (mm)		Type	Gasket Mould No.	Weight (kg)
	Min	Max									Min	Max			
50	43.5	63.5	50	PN10/PN16	17.0	4-M12 x 125	151	167	131	80 x 6	25	35	1	6010	4.4
65	63.0	83.7	65	PN10/PN16	17.0	4-M12 x 125	171	185	132	80 x 6	25	35	1	6011	5.1
80	85.7	107.0	80	PN10/PN16	17.0	4-M12 x 145	192	200	154	100 x 6	30	60	1	6012	5.8
100	107.2	133.2	100	PN10/PN16	18.0	4-M16 x 180	231	234	191	130 x 6	57	85	2	6013	8.6
125	132.2	160.2	125	PN10/PN16	18.0	4-M16 x 160	265	268	171	111 x 6	28	65	1	6014	9.8
150	158.2	192.2	150	PN10/PN16	18.0	4-M16 x 210	303	317	220	150 x 6	70	100	2	6015	14.17
175*	192.2	226.9	200	PN10/PN16	18.0	4-M16 x 190	344	344	201	132 x 7	25	80	1	6030	17.2
200	218.1	252.1	200	PN10/PN16	18.0	4-M16 x 230	369	374	241	180 x 7	75	130	2	6016	20.4
250	266.2	300.2	250	PN10/PN16	20.0	6-M16 x 270	417	424	281	212 x 7	80	160	2	6017	27.5
300	315.0	349.0	300	PN10/PN16	21.5	6-M16 x 270	466	472	281	211 x 8	80	160	2	6018	34.3

*DN175 MegaDaptor supplied with DN200 flange.

Bolt Torques	
	Nm
M12	55 - 65
M16	95 - 110

Materials & Relevant Standards

Centre Sleeve/End Rings*

SG ductile iron BS EN 1563, EN GJS-450-10

Flange Adaptor Body*

SG ductile iron BS EN 1563, EN GJS-450-10

Bolts/Nuts/Washers

Bolts - Steel to BS EN ISO 898 Property Class Grade 8.8 equivalent DIN 267 - Part 3:Class 8.8

Nuts - Steel to BS EN20898-2 Property Class 8.0

Washers - Stainless Steel to BS 1449:Pt2 grade 304 S15

Coatings

Flange adaptor body, Part centre sleeve, end rings are coated in Rilsan Nylon 11 to WIS 4-52-01

As standard, all bolts and nuts are Sheraplex coated, which is a compound of zinc sheradising and low friction polymeric coating that meets WIS 4-52-03

Gasket

EPDM compound Grade 'E' to BS EN 681-1 WRAS approved, or nitrile compound to DIN 3535-3

'E' temperature range: -40°C to +90°C. Suitable for water, sewage, many strong and oxidising chemicals, food applications

Nitrile temperature range: -20°C to +100°C. Suitable for natural gas, petroleum products, low aromatic fuels and compressed air (Not suitable for fluctuating temperature, e.g. heating systems)

Approvals/Standards

All MegaFit products are designed and manufactured under quality management systems certified to BS EN ISO 9001, have been tested to the UK Water Regulations Advisory Scheme and conform to the American Water Works Association's standard AWWA/ANSI C.219 for bolted couplings

* Materials of construction at the discretion of Viking Johnson. Viking Johnson reserves the right to modify the details in this publication as products and specifications are updated and improved.

Every effort has been made to ensure that the information contained in this publication is accurate at the time of publishing. Crane Ltd assumes no responsibility or liability for typographical errors or omissions or for any misinterpretation of the information within the publication and reserves the right to change without notice.