

# MaxiDaptor Large Diameter Flange Adaptor ANSI Flange Drilling

## Specifications

- 1 = Adaptor Body
- 2 = End Ring
- 3 = Gasket
- 4 = Stud, Nut & Washer

Working Pressure = 16bar (water)  
6bar (gas)

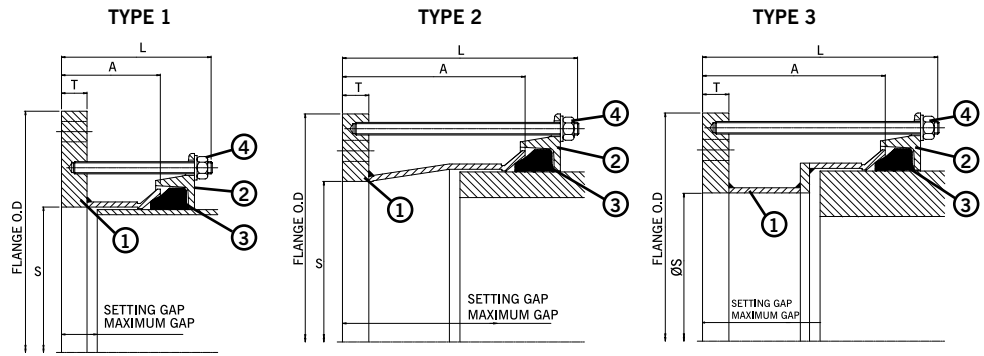

## Flange Adaptor ANSI

OD Range		Flange Details								Gasket Mould No.	Studs No.-Dia x Length	Setting Gap		Weight (kg)
Min (mm)	Max (mm)	Nom.	Drilling	Flange Diameter OD (mm)	Flange Bore S (mm)	Flange Thickness T (mm)	Type	Sleeve Length A (mm)	Overall Length L (mm)			Min (mm)	Max (mm)	
351.0	368.0	14"	ANSI150	533.0	370.0	25	1	120	218	6002	6-M12 x 205	45	68	35.9
374.5	391.5	14"	ANSI150	533.0	393.5	25	1	120	218	1659	6-M12 x 205	45	68	34.0
386.0	403.0	14"	ANSI150	533.0	397.5	25	2	205	218	6035	6-M12 x 290	130	153	39.0
394.3	411.3	14"	ANSI150	533.0	397.5	25	2	205	218	1766	6-M12 x 290	130	153	39.2
404.8	421.8	16"	ANSI150	597.0	424.0	25	1	120	218	1767	8-M12 x 205	45	68	42.2
425.0	442.0	16"	ANSI150	597.0	444.0	25	1	120	218	1662	8-M12 x 205	45	68	40.3
434.4	451.4	16"	ANSI150	597.0	453.5	25	1	120	303	1768	8-M12 x 205	45	68	39.4
439.0	456.0	16"	ANSI150	597.0	458.0	25	1	120	303	6036	8-M12 x 205	45	68	39.0
447.2	464.2	16"	ANSI150	597.0	448.0	25	2	205	303	1769	8-M12 x 290	130	153	46.3
455.0	472.0	16"	ANSI150	597.0	448.0	25	2	205	303	6003	8-M12 x 290	130	153	46.4
455.0	472.0	18"	ANSI150	635.0	474.0	25	1	120	303	6003	8-M12 x 205	45	68	44.0
487.3	504.3	18"	ANSI150	635.0	499.0	25	2	205	303	1771	8-M12 x 290	130	153	47.8
492.0	509.0	18"	ANSI150	635.0	499.0	25	2	205	303	6037	8-M12 x 290	130	153	47.8
501.9	518.9	18"	ANSI150	635.0	499.0	25	2	205	303	1772	8-M12 x 290	130	153	48.0
510.0	527.0	18"	ANSI150	637.0	499.0	25	2	205	303	6004	8-M12 x 290	130	153	48.6
527.0	544.0	20"	ANSI150	698.0	546.0	25	1	120	303	1773	10-M12 x 205	45	68	47.9
540.1	557.1	20"	ANSI150	698.0	550.0	25	2	205	303	1774	10-M12 x 290	130	153	54.4
546.0	563.0	20"	ANSI150	698.0	550.0	25	2	205	303	6038	10-M12 x 290	130	153	54.8
555.3	572.3	20"	ANSI150	698.0	550.0	25	2	205	303	1775	10-M12 x 290	130	153	55.0
565.0	582.0	20"	ANSI150	698.0	550.0	25	2	205	303	1776	10-M12 x 290	130	153	55.1
582.2	599.2	20"	ANSI150	709.0	550.0	25	2	205	303	1777	10-M12 x 290	130	153	57.8
601.0	618.0	24"	ANSI150	813.0	620.0	25	1	120	218	6020	10-M12 x 205	45	68	63.3
630.0	647.0	24"	ANSI150	813.0	649.0	25	1	120	303	1778	10-M12 x 205	45	68	58.7
645.2	662.2	24"	ANSI150	813.0	653.0	25	2	205	303	1779	10-M12 x 290	130	153	66.7
654.0	671.0	24"	ANSI150	813.0	653.0	25	2	205	303	6039	10-M12 x 290	130	153	66.9
662.0	679.0	24"	ANSI150	813.0	653.0	25	2	205	303	1780	10-M12 x 290	130	153	67.0
675.0	692.0	24"	ANSI150	813.0	653.0	25	2	205	303	6005	10-M12 x 290	130	153	67.3

## Materials & Relevant Standards

### Flange Adaptor Body

Mild Steel to BS EN 10025-2 Grade S275

### End Ring

Rolled Steel to BS EN 10025-2 Grade S275

### Gasket

EPDM Grade "E" to BS EN 681-1 Type WA WRAS Listed

### Bolt Torque / Spanner

Bolt torque - 55-65Nm / Spanner size - A/F 19mm

### Studs, Nuts & Washer

**Studs** - Steel to BS EN ISO 898-1 Property Class 4.8

**Nuts** - Steel to BS EN 4190 Grade 4

**Washer** - Stainless Steel to BS 1449:Part 2 Grade 304 S15

### Coating

**Flange Adaptor Body & End Ring** = Rilsan Nylon 11 to WIS 4-52-01 Part 1

**Bolts & Nuts** = Sheraplex to WIS 4-52-03

Every effort has been made to ensure that the information contained in this publication is accurate at the time of publishing. Crane Ltd assumes no responsibility or liability for typographical errors or omissions or for any misinterpretation of the information within the publication and reserves the right to change without notice.