

MaxiDaptor Large Diameter Flange Adaptor PN10

Specifications

- 1 = Adaptor Body
- 2 = End Ring
- 3 = Gasket
- 4 = Stud, Nut & Washer

Working Pressure = 16bar (water)
6bar (gas)

Flange Adaptor PN10

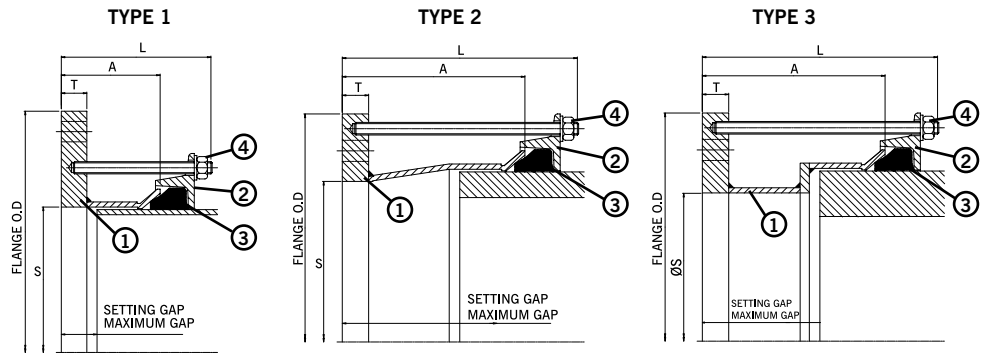

OD Range		Flange Details									Gasket Mould No.	Studs No.-Dia x Length	Setting Gap		Weight (kg)
Min (mm)	Max (mm)	Nom.	Drilling	Flange Diameter OD (mm)	Flange Bore S (mm)	Flange Thickness T (mm)	Type	Sleeve Length A (mm)	Overall Length L (mm)	Min (mm)			Max (mm)		
487.3	504.3	500	PN10	670.0	500.0	23	1	120	218	1771	10-M12 x 205	45	68	46.4	
492.0	509.0	500	PN10	670.0	511.0	23	1	120	218	6037	10-M12 x 205	45	68	45.0	
501.9	518.9	450	PN10	630.0	450.0	23	2	205	303	1772	10-M12 x 290	130	153	52.3	
501.9	518.9	450	PN10	615.0	485.5	23	2	205	303	1772	10-M12 x 290	130	153	47.6	
501.9	518.9	500	PN10	670.0	500.0	23	1	120	218	1772	10-M12 x 205	45	68	47.0	
501.9	518.9	500	PN10	670.0	521.0	23	1	120	218	1772	10-M12 x 205	45	68	43.9	
510.0	527.0	450	PN10	637.0	450.0	23	2	205	303	6004	10-M12 x 290	130	153	53.9	
510.0	527.0	450	PN10	637.0	494.0	23	2	205	303	6004	10-M12 x 290	130	153	48.0	
510.0	527.0	500	PN10	670.0	500.0	23	1	120	220	6004	10-M12 x 205	45	68	47.2	
527.0	544.0	500	PN10	670.0	500.0	23	1	120	218	1773	10-M12 x 205	45	68	47.8	
527.0	544.0	500	PN10	670.0	546.0	23	1	120	218	1773	10-M12 x 205	45	68	47.1	
540.1	557.1	450	PN10	667.0	450.0	23	3	250	338	1774	10-M12 x 325	175	198	71.2	
540.1	557.1	500	PN10	670.0	500.0	23	2	205	303	1774	10-M12 x 290	130	153	55.0	
540.1	557.1	500	PN10	670.0	550.0	23	2	205	303	1774	10-M12 x 290	130	153	47.6	
555.3	572.3	500	PN10	684.0	500.0	23	2	205	303	1775	10-M12 x 290	130	153	58.2	
555.3	572.3	500	PN10	684.0	550.0	23	2	205	303	1775	10-M12 x 290	130	153	50.8	
566.5	583.5	500	PN10	694.0	500.0	23	2	205	303	1776	10-M12 x 290	130	153	60.5	
566.5	583.5	500	PN10	694.0	550.0	23	2	205	303	1776	10-M12 x 290	130	153	53.1	
582.2	599.2	500	PN10	709.0	500.0	23	3	205	303	1777	10-M12 x 290	130	153	72.6	
582.2	599.2	500	PN10	670.0	540.0	23	3	205	303	1777	10-M12 x 290	130	153	64.5	
582.2	599.2	600	PN10	780.0	600.0	25	1	120	218	1777	10-M12 x 205	45	68	59.1	
601.0	618.0	500	PN10	728.0	500.0	23	3	255	338	6020	10-M12 x 325	180	203	81.3	
601.0	618.0	600	PN10	780.0	600.0	25	1	120	218	6020	10-M12 x 205	45	68	59.8	
618.0	635.0	600	PN10	780.0	600.0	23	1	120	218	6025	10-M12 x 205	45	68	57.5	
630.0	647.0	600	PN10	780.0	600.0	23	1	120	218	1778	10-M12 x 205	45	68	58.0	
630.0	647.0	600	PN10	780.0	649.0	23	1	120	218	1778	10-M12 x 205	45	68	49.4	
645.2	662.2	600	PN10	780.0	600.0	23	2	205	303	1779	10-M12 x 290	130	153	66.8	
645.2	662.2	600	PN10	780.0	649.0	23	2	205	303	1779	10-M12 x 290	130	153	58.1	
662.0	679.0	600	PN10	790.0	600.0	23	2	205	298	1780	10-M12 x 290	130	153	69.3	
662.0	679.0	600	PN10	790.0	653.0	23	2	205	303	1780	10-M12 x 290	130	153	60.0	
675.0	692.0	600	PN10	802.0	600.0	23	2	205	303	6005	10-M12 x 290	130	153	72.3	
675.0	692.0	600	PN10	802.0	653.0	23	2	205	303	6005	10-M12 x 290	130	153	63.0	
689.0	706.0	600	PN10	816.0	600.0	23	3	260	338	10511/49	10-M12 x 325	185	210	90.3	
695.0	712.0	700	PN10	895.0	714.0	23	1	120	218	6063	12-M12 x 205	45	68	66.1	
699.0	716.0	700	PN10	895.0	718.0	23	1	120	218	10511/50	12-M12 x 205	45	68	65.5	

Materials & Relevant Standards

Flange Adaptor Body

Mild Steel to BS EN 10025-2 Grade S275

End Ring

Rolled Steel to BS EN 10025-2 Grade S275

Gasket

EPDM Grade "E" to BS EN 681-1 Type WA WRAS Listed

Bolt Torque / Spanner

Bolt torque - 55-65Nm / Spanner size - A/F 19mm

Studs, Nuts & Washer

Studs - Steel to BS EN ISO 898-1 Property Class 4.8

Nuts - Steel to BS EN 4190 Grade 4

Washer - Stainless Steel to BS 1449:Part 2 Grade 304 S15

Coating

Flange Adaptor Body & End Ring = Rilsan Nylon 11 to WIS 4-52-01 Part 1

Bolts & Nuts = Sheraplex to WIS 4-52-03

Every effort has been made to ensure that the information contained in this publication is accurate at the time of publishing. Crane Ltd assumes no responsibility or liability for typographical errors or omissions or for any misinterpretation of the information within the publication and reserves the right to change without notice.