

Dismantling Joint DN350 to DN1800 (PN25)

Specifications

Note: Maximum Longitudinal Adjustment
= Maximum Length – Minimum Length

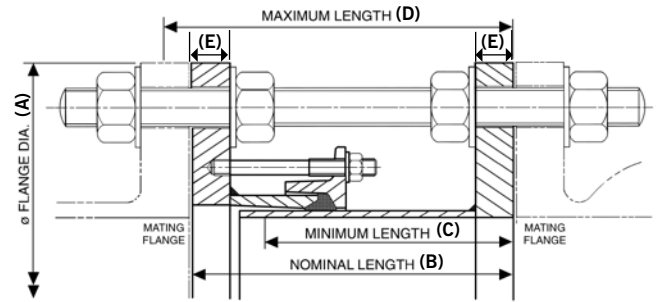

Dismantling Joint

Flange Details		Flange To Flange Details				Tie Rod Details						
Nom	Drilling	Flange Thickness	Flange OD	Nominal Length	Minimum Length	Maximum Length	Steel Tie Rod			Stainless Steel Tie Rod		
		E (mm)	A (mm)	B (mm)	C (mm)	D (mm)	Dia x Length (mm)	No.	Total Weight of DJ (kg)	Dia x Length (mm)	No.	Total Weight of DJ (kg)
350	PN25	25	555	302	277	327	M30 x 480	4	91.1	M30 x 480	4	91.1
400	PN25	25	620	302	277	327	M33 x 490	4	109.0	M33 x 490	4	109.0
450	PN25	25	670	302	277	327	M33 x 500	5	122.0	M33 x 500	5	122.0
500	PN25	25	730	302	277	327	M33 x 510	5	137.0	M33 x 510	5	137.0
550	PN25	25	785	302	277	327	M36 x 530	5	155.0	M36 x 530	5	155.0
600	PN25	25	845	302	277	327	M36 x 540	5	170.0	M36 x 540	6	177.0
650	PN25	25	895	307	277	337	M36 x 550	6	199.0	M36 x 550	8	211.0
700	PN25	25	960	302	277	327	M39 x 570	6	212.0	M39 x 570	8	227.0
800	PN25	25	1085	307	277	337	M45 x 630	6	279.0	M45 x 630	8	302.0
900	PN25	25	1185	307	277	337	M45 x 630	7	317.0	M45 x 630	10	350.0
1000	PN25	38	1320	320	290	350	M52 x 660	7	520.0	M52 x 740	8	567.0
1200	PN25	38	1530	320	290	350	M52 x 690	8	637.0	M52 x 770	12	724.0
1400	PN25	60	1755	462	412	512	M56 x 890	9	1,181.0	M56 x 980	14	1,369.0
1600	PN25	60	1975	462	412	512	M56 x 920	10	1,514.0	M56 x 1010	16	1,740.0
1800	PN25	60	2185	462	412	512	M64 x 970	11	1,855.0	M64 x 1075	16	1,970.0

Materials & Relevant Standards

Flange Drilling

BS EN1092-1 (formerly BS4504), ISO7005

Fabricated Flange Adaptor

Body - Rolled Steel to BS EN 10025-2: Grade S275

End Rings/Sleeve - Rolled Steel to BS EN 10025-2: Grade S275

or Rolled Steel to BS EN 10025-2: Grade S355 (depending on section)

Flanged Spigot

Flange - Rolled Steel to BS EN 10025-2: Grade S275

Spigot - Steel Tube to BS10216-1: Grade P265TR1

or Rolled Steel to BS EN 10025-2: Grade S275

Gaskets

BS EN681-1: Type WA WRAS listed

Steel Tie Rods & Nuts

Tie Rods - BS EN10269: Name 42CrMo4 (Yield 725N/mm²) (formerly MB7)

Nuts - BS EN20898-2: Property Class 8.0

Stainless Steel Tie Rods & Nuts

Tie Rods - Stainless Steel to BS EN3506-1: Grade A2/A4 Property Class 70 (Yield 450N/mm²)

Nuts (sizes up to & including M48) 4 per Tie Rod - Stainless Steel to BS EN3506-2: Grade A2/A4 Property Class 80

Nuts (sizes over M48) 6 per Tie Rod - Stainless Steel to BS EN3506-2: Grade A2/A4 Property Class 50

Studs/Nuts/Washers

Studs - Steel to BS EN ISO898-1: Property Class 4.8

Nuts - Steel to BS4190: Grade 4

Washers - Stainless Steel to BS1449:Part 2: Grade 304S15

Coatings (Others available on request)

Fabricated Flange Adaptor - Rilsan Nylon 11

Flanged Spigot - Rilsan Nylon 11

End Ring - Rilsan Nylon 11

Studs/Nuts - Sheraplex to WIS 4-52-03

Steel Tie Rods/Nuts - Zn3 Zinc coated

Every effort has been made to ensure that the information contained in this publication is accurate at the time of publishing. Crane Ltd assumes no responsibility or liability for typographical errors or omissions or for any misinterpretation of the information within the publication and reserves the right to change without notice.