

# Dismantling Joint DN40 to DN300 (PN10,16,25,40)

## Specifications

Note: Maximum Longitudinal Adjustment  
= Maximum Length – Minimum Length

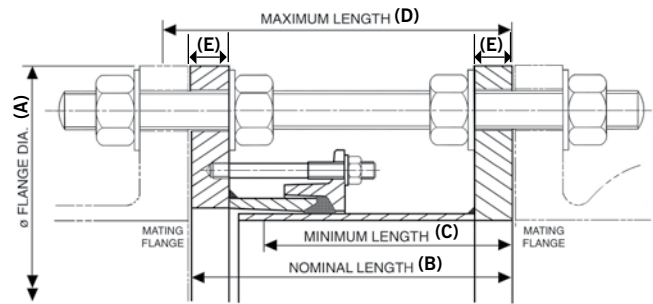

## Dismantling Joint

Flange Details				Flange to Flange Details				Tie Rod Details					Flange Adaptor Method of Construction Cast / Fabricated	
Nom	Drilling	Flange Thickness		Flange OD	Nominal Length	Minimum Length	Maximum Length	Steel Tie Rod			Stainless Steel Tie Rod			
		Flange Adaptor E (mm)	Spigot E (mm)	A (mm)	B (mm)	C (mm)	D (mm)	Dia x Length (mm)	No.	Total Weight of DJ (kg)	Dia x Length (mm)	No.	Total Weight of DJ (kg)	
40	PN10,16,25,40	18	18	150	187	167	207	M16 x 300	4	7.8	M16 x 300	4	7.8	Fabricated
50	PN10,16,25,40	17	18	165	194	174	214	M16 x 300	4	8.2	M16 x 300	4	8.2	Cast
65	PN10,16	17	18	185	194	174	214	M16 x 300	4	9.4	M16 x 300	4	9.3	Cast
80	PN10,16,25,40	17	18	200	194	174	214	M16 x 300	4	10.4	M16 x 300	4	10.4	Cast
100	PN10,16	17	18	220	194	174	214	M16 x 300	4	11.6	M16 x 300	4	11.6	Cast
100	PN25,40	25	25	235	194	174	214	M20 x 320	4	19.2	M20 x 320	4	19.2	Fabricated
125	PN10,16	17	18	250	194	174	214	M16 x 300	4	13.5	M16 x 300	4	13.5	Cast
125	PN25,40	25	25	270	194	174	214	M24 x 330	4	26.2	M24 x 330	4	26.2	Fabricated
150	PN10,16	17	18	285	194	174	214	M20 x 310	4	17.7	M20 x 310	4	17.7	Cast
150	PN25	25	25	300	194	174	214	M24 x 330	4	28.9	M24 x 330	4	28.9	Fabricated
150	PN40	25	25	300	194	174	214	M24 x 330	4	28.8	M24 x 330	4	28.8	Fabricated
200	PN10	20	18	340	194	174	214	M20 x 310	4	24.3	M20 x 310	4	24.3	Cast
200	PN16	20	18	340	194	174	214	M20 x 310	4	24.1	M20 x 310	4	24.1	Cast
200	PN25	25	25	360	194	174	214	M24 x 340	4	37.5	M24 x 340	4	37.5	Fabricated
200	PN40	25	25	375	194	174	214	M27 x 350	4	42.6	M27 x 350	4	42.6	Fabricated
250	PN10	19	18	395	194	174	214	M20 x 310	4	29.6	M20 x 310	4	29.6	Cast
250	PN16	19	18	405	194	174	214	M24 x 330	4	32.8	M24 x 330	4	32.8	Cast
250	PN25	25	25	425	194	174	214	M27 x 350	4	49.1	M27 x 350	4	49.1	Fabricated
250	PN40	25	25	450	194	174	214	M30 x 370	4	57.9	M30 x 370	4	57.9	Fabricated
300	PN10	19	18	445	194	174	214	M20 x 310	4	36.2	M20 x 310	4	36.2	Cast
300	PN16	19	18	460	194	174	214	M24 x 330	4	40.0	M24 x 330	4	40.0	Cast
300	PN25	25	25	485	194	174	214	M27 x 350	4	57.1	M27 x 350	4	57.1	Fabricated
300	PN40	25	25	515	194	174	214	M30 x 380	4	69.8	M30 x 380	4	69.8	Fabricated

## Materials & Relevant Standards

### Flange Drilling

BS EN1092-1 (formerly BS4504), ISO7005

### Cast Flange Adaptor

**Body** - Ductile Iron to BS EN1563:  
Symbol EN-GJS-450-10

**End Rings** - Ductile Iron to BS EN1563:  
Symbol EN-GJS-450-10

### Fabricated Flange Adaptor

**Body** - Rolled Steel to BS EN 10025-2:  
Grade S275

**End Rings** - Rolled Steel to BS EN 10025-2:  
Grade S275

**Sleeve** - Steel Tube to BS EN10255:  
or Steel Tube to BS EN10216-1: Grade  
P265TR1 or Rolled Steel to BS EN 10025-2:  
Grade S275

### Flanged Spigot

**Flange** - Rolled Steel to BS EN 10025-2:  
Grade S275

**Spigot** - Steel Tube to BS EN10255:  
or Steel Tube to BS EN10216-1: Grade  
P265TR1 or Rolled Steel to BS EN 10025-2:  
Grade S275

### Gaskets

BS EN681-1: Type WA WRAS listed

### Steel Tie Rods & Nuts

**Tie Rods** - BS EN10269:+A1: Name 42CrMo4  
(Yield 725N/mm<sup>2</sup>) (formerly MB7)

**Nuts** - BS EN20898-2: Property Class 8.0

### Stainless Steel Tie Rods & Nuts

**Tie Rods** - Stainless Steel to BS EN3506-1:  
Grade A2/A4 Property Class 70  
(Yield 450N/mm<sup>2</sup>)

**Nuts 4 per Tie Rod** - Stainless Steel to BS  
EN3506-2: Grade A2/A4 Property Class 80

### Studs/Nuts/Washers

**Studs** - Steel to BS EN ISO898-1:  
Property Class 4.8

**Nuts** - Steel to BS4190: Grade 4

**Washers** - Stainless Steel to BS1449:Part 2:  
Grade 304S15

### Coatings (Others available on request)

**Flange Adaptor** - Rilsan Nylon 11

**Flanged Spigot** - Rilsan Nylon 11

**End Ring** - Rilsan Nylon 11

**Studs/Nuts** - Sheraplex to WIS 4-52-03

**Steel Tie Rods/Nuts** - Zn3 Zinc coated

Every effort has been made to ensure that the information contained in this publication is accurate at the time of publishing. Crane Ltd assumes no responsibility or liability for typographical errors or omissions or for any misinterpretation of the information within the publication and reserves the right to change without notice.