

Dismantling Joint 3" to 40" (ANSI 300)

Specifications

Note: Maximum Longitudinal Adjustment
= Maximum Length – Minimum Length

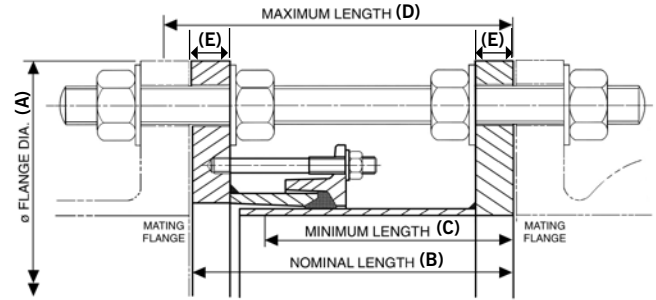

Dismantling Joint

Flange Details			Flange To Flange Details				Tie Rod Details				
Nom	Drilling	Flange Thickness E (mm)	Flange OD	Nominal Length	Minimum Length	Maximum Length	Tie Rod Dia x Length	H.T Zinc Plated Steel H.T Steel BS4882 Grade MB7 Yield 725N/mm ²		Stainless Steel Class 70 Yield 450N/mm ²	
			A (mm)	B (mm)	C (mm)	D (mm)		No.	Total Weight of DJ (kg)	No.	Total Weight of DJ (kg)
3"	ANSI 300	25	210	194	174	214	3/4" x 13"	4	19.3	4	19.3
4"	ANSI 300	25	254	194	174	214	3/4" x 13"	4	26.2	4	26.2
6"	ANSI 300	25	318	194	174	214	3/4" x 13 1/2"	4	32.1	4	32.1
8"	ANSI 300	25	381	194	174	214	7/8" x 14 1/2"	4	43.1	4	43.1
10"	ANSI 300	25	444	194	174	214	1" x 15"	4	63.0	6	60.8
12"	ANSI 300	25	521	194	174	214	1 1/8" x 16"	4	74.1	6	80.2
14"	ANSI 300	25	584	307	277	337	1 1/8" x 20 1/2"	5	117.0	8	129.0
16"	ANSI 300	25	648	307	277	337	1 1/4" x 21 1/2"	5	138.0	8	151.5
18"	ANSI 300	38	711	320	290	350	1 1/4" x 22"	6	220.0	10	241.0
20"	ANSI 300	38	775	320	290	350	1 1/4" x 22 1/2"	8	262.0	12	284.0
24"	ANSI 300	38	914	320	290	350	1 1/2" x 23 1/2"	8	359.0	12	393.0
28"	ANSI 300	38	1035	320	290	350	1 5/8" x 25"	7	427.0	12	489.0
30"	ANSI 300	38	1092	320	290	350	1 3/4" x 26"	8	500.0	12	551.0
32"	ANSI 300	38	1149	320	290	350	1 7/8" x 26 1/2"	8	546.0	14	646.0
36"	ANSI 300	38	1270	320	290	350	2" x 28"	10	676.0	14	749.0
40"	ANSI 300	60	1238	462	412	512	1 5/8" x 33 1/2"	16	844.0	26	958.0

Materials & Relevant Standards

Flange Drilling

ASME/ANSI B16.5/B16.47

Fabricated Flange Adaptor

Body - Rolled Steel to BS EN 10025-2: Grade S275

End Rings - Ductile Iron to BS EN1563: Symbol EN-GJS-450-10
or Rolled Steel to BS EN 10025-2: Grade S275

Sleeve - Steel Tube to BS EN10255:

or Steel Tube to BS EN10216-1: Grade P265TR1

or Rolled Steel to BS EN 10025-2: Grade S275

or Rolled Steel to BS EN 10025-2: Grade S355 (depending on section)

Flanged Spigot

Flange - Rolled Steel to BS EN 10025-2: Grade S275

Spigot - Steel Tube to BS EN10255:

or Steel Tube to BS EN10216-1: Grade P265TR1

Gaskets

BS EN681-1:1996 Type WA WRAS listed

Steel Tie Rods & Nuts

Tie Rods - BS EN10269: Name 42CrMo4 (Yield 725N/mm²) (formerly B7)

Nuts - BS EN20898-2: Property Class 8.0

Stainless Steel Tie Rods & Nuts

Tie Rods - Stainless Steel to BS EN3506-1: Grade A2/A4 Property Class 70 (Yield 450N/mm²)

Nuts (sizes up to and including 2 1/4") 4 per Tie Rod - Stainless Steel to BS EN3506-2: Grade A2/A4 Property Class 80

Nuts (sizes over 2 1/4") 6 per Tie Rod - Stainless Steel to BS EN3506-2: Grade A2/A4 Property Class 50

Studs/Nuts/Washers

Studs - Steel to BS EN ISO898-1: Property Class 4.8

Nuts - Steel to BS4190: Grade 4

Washers - Stainless Steel to BS1449:Part 2: Grade 304S15

Coatings (Others available on request)

Fabricated Flange Adaptor - Rilsan Nylon 11

Flanged Spigot - Rilsan Nylon 11

End Ring - Rilsan Nylon 11

Studs/Nuts - Sheraplex to WIS 4-52-03

Steel Tie Rods/Nuts - Zn3 Zinc coated

Every effort has been made to ensure that the information contained in this publication is accurate at the time of publishing. Crane Ltd assumes no responsibility or liability for typographical errors or omissions or for any misinterpretation of the information within the publication and reserves the right to change without notice.