

# Next Generation UltraGrip Pecatadaptors & End Caps

## Specifications

### Pecatadaptors

► Length of PE will accommodate two electrofusion connections

► Up to 4° angular deflection on UltraGrip end

Nom Size	Size Range		PE		Insertion Depth (D)		Dimensions			Bolts		Weight Kg
							Overall		PE Pipe End	Size	Type	
	Min	Max	Size	Sdr	Min	Max	A	B	L			
80	85.7	107.0	90	11	65	95	212	682	496	3-M12x70	HRH	7.43
100	107.0	133.2	110	11	90	115	280	708	496	3-M16x93	CSX	12.23
100	107.0	133.2	125	11	90	115	280	701	496	3-M16x93	CSX	12.92
125	132.2	160.2	110	11	90	115	305	727	496	3-M16x93	CSX	13.84
125	132.2	160.2	125	11	90	115	305	721	496	3-M16x93	CSX	14.56
150	158.2	192.2	160	11	90	125	339	730	496	4-M16x93	CSX	20.7
150	158.2	192.2	180	11	90	125	339	727	496	4-M16x93	CSX	23.27
200	218.1	256.0	225	11	125	165	432	751	496	5-M16x93	CSX	36.22

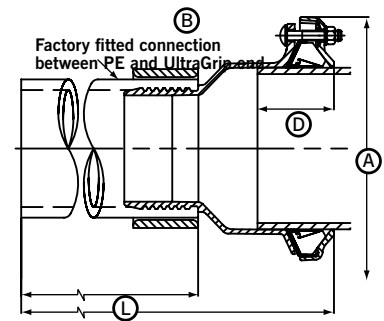

### End Caps

► Optional - drilled and tapped bosses available:

- Axial – to act as inlet/drainage point (Min=1/2", Max=2" - all sizes)
- Radial – to act as air release/bleed hole (Min=1/2", Max=2" - depending on diameter)

► Up to 4° angular deflection

► End caps supplied with Sheraplex coated steel bolts to allow repeated use without the need to lubricate threads. Stainless steel bolts are optional

Nom Size	Size Range		Insertion Depth (D)		Boss				Dimensions		Bolts		Weight Kg
					Axial		Radial		A	B	No-size	Type	
	Min	Max	Min	Max	Min BSP	Max BSP	Min BSP	Max BSP					
40	43.5	63.5	65	95	1/2"	2"	1/2"	3/4"	168	150	3-M12x70	CSX	3.34
65	63.0	83.7	65	95	1/2"	2"	1/2"	3/4"	189	150	3-M12x70	CSX	3.97
80	85.7	107.0	65	110	1/2"	2"	1/2"	3/4"	212	166	3-M12x70	CSX	4.84
100	107.0	133.2	90	125	1/2"	2"	1/2"	1"	280	197	3-M16x93	CSX	8.44
125	132.2	160.2	90	135	1/2"	2"	1/2"	1"	305	215	3-M16x93	CSX	10.12
150	158.2	192.2	90	135	1/2"	2"	1/2"	1"	339	219	4-M16x93	CSX	12.6
175	192.2	226.9	125	165	1/2"	2"	1/2"	1"	403	235	5-M16x93	CSX	19.54
200	218.1	256.0	125	165	1/2"	2"	1/2"	1 1/2"	432	237	5-M16x93	CSX	21.4
250	266.2	310.0	125	165	1/2"	2"	1/2"	2"	476	309	6-M16x120	CSX	32.46
300	315.0	356.0	125	200	1/2"	2"	1/2"	2"	522	310	8-M16x120	CSX	39.21

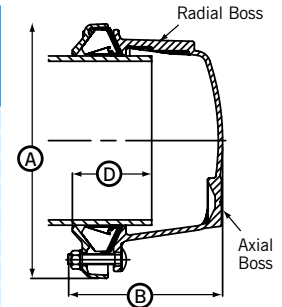

### Working Pressure & Temperature Ratings

Nominal Size	Gripping Product		Flex Product		Operating Temperature
	Gas	Water	Gas	Water	
DN40 to DN300	5bar	16bar	5bar	16bar	-20°C to +30°C
DN350 to DN400	5bar	10bar	5bar	10bar	
DN450 to DN600	N/A	10bar	N/A	10bar	

#### Notes:

- 1) Site Test Pressure – 1.5 times working pressure.
- 2) Factory Test Pressure – The minimum requirement in European Standards is 1.5 times working pressure plus 5bar (e.g. 29bar for 16bar working pressure), but in many cases Viking Johnson reaches substantially higher levels – up to 36bar.
- 3) All water contact components are approved for use with Potable Water.

#### Bolt Torque

	Nm
<b>M12</b>	55 - 70
<b>M16</b>	95 - 120
<b>M20</b>	200 - 225

## UltraGrip Product Notes

### Gripping product suitable for

Steel/Ductile iron/Grey cast iron/ PE/PVC

### Flex product suitable for

Steel/Ductile iron/Grey cast iron/ PVC/Asbestos cement

### Support liners – PE and PVC pipes

A close fit support liner is required when used on:

- All PE pipes
- Thin walled PVC pipes

## Materials & Relevant Standards

### End Rings, Pecatadaptor Body, End Cap

S.G. Iron to BS EN 1563 Symbol EN-GJS-450-10

### Gaskets

**EPDM:** EPDM Compound Grade E to

BS EN 681-1 WA KTW & DVGW approved

**NBR:** Nitrile Compound EN682 DVGW Approved

### Gripper and Carrier

Acetal Copolymer Grade M25 or equivalent

### Bolts/Nuts/Washers

**Bolts** - Stainless steel to BS EN 3506-1 Grade A2 Property Class 80 or 70

**Nuts** - Stainless Steel to BS EN 3506-2 Grade A4 Property Class 80 Steel to BS EN 20898-2 Property Class 8.0

**Washer** - Stainless steel – BS1449:PT2 Grade 304 S15

### Completion Sleeve to Pecatadaptor

Mild Steel Tube to DIN1629 Grade ST52 or ST37-2

### PE Pipe for Pecatadaptor

Pipe used for Pecatadaptor is black PE100 SDR 11

### Coatings

**Cast/Metal Components** - Rilsan Nylon 11 (Black)

**Bolts** - Dry Film Lubricant

**Nuts** - Dacromet coated

### Approvals

**Rilsan Nylon 11 (Black):**

WRAS approved for use with potable water

Gasket: WRAS as well as KTW, DVGW & W270 approvals

When used on thick walled PVC pipes a support liner is not required. Please contact Viking Johnson for further details.

### Use of restrained couplings on exposed pipework

Above ground exposed pipework is subject to both loads from the internal pressure and those from temperature changes / thermal expansion, which can be substantially higher than those from internal pressure and cannot always be safely determined. For this reason it is recommended that the use of UltraGrip be restricted to buried pipelines, valve chambers and above ground indoor applications and not exposed to direct sunlight or excessive temperature changes (e.g. pump houses).